



Model GP

Pneumatic Actuated

3-Way Control Valves

FEATURES

- FAIL-SAFE, SPRING RETURN ACTUATOR
- ACCURATE AND REPEATABLE TEMPERATURE CONTROL
- LOW PRESSURE DROP
- SELECTABLE DIRECTION OF ROTATION
- VIBRATION RESISTANT
- MOUNT IN ANY POSITION
- COMPACT DESIGN
- NEMA 4 WEATHER PROOF CONSTRUCTION
- POSITION INDICATOR
- SIZES 2" TO 16"
- 40 GPM TO 8300 GPM

APPLICATIONS

For Refineries, Chemical Plants & Oil Reproduction:

- ~ Waste Heat Boilers
- ~ Product Coolers
- ~ Product Heaters
- ~ Product Condensers

For Engines, Turbines, Gear Boxes & Heat Exchanges:

- ~ Charge Air Cooling
- ~ Secondary Cooling Systems
- ~ Fuel & Lube Oil Preheating
- ~ Co-Generation
- ~ Engine Jacket Water



AMOT Model GP Valves are 3-way control valves consisting of a heavy duty rotary valve and a quarter turn pneumatic actuator. Model GP valves provide a high degree of accuracy and repeatability for accurate temperature control. The valves are equally accurate in mixing or diverting service over a wide flow range. The heavy duty rotor design provides tight temperature control without high maintenance requirements.

Designed for high vibration service, the valves are qualified to Lloyd's Marine requirements for shipboard service. Valves can be directly mounted to reciprocating machinery such as diesel engines without vibration isolation. The heavy duty actuators are specially reinforced to provide vibration resistance.

The standard valves are suitable for a variety of fluids such as water, water/glycol, sea water, lubricating and hydraulic oils. Optional body and seal materials are available for services involving synthetic or fire resistant oils, deionized water and ammonia or freon in oil.

The compact design of the valves minimizes the installation space required. Combined with selectable direction of rotation and mode of operation, piping design can be simplified providing low installation cost. The internal design provides unobstructed full flow keeping the pressure drop across the valve between 0.15 to 1.5 psig.

Used in conjunction with the proven AMOT Pneumatic or Electronic Controller, the complete system provides simplicity of operation and tight control of temperature.

SPECIFICATIONS

Valve

Body See Table C "Model Code System"
 Rotor material:
 All except Steel body Bronze
 Steel body Stainless Steel
 Rotor shaft material: Stainless Steel
 Shaft seals material: Standard Buna N
 Optional Viton
 Flanges: See Table D "Model Code System"
 Maximum working pressure: Cast Iron/Bronze 145 psi
 Steel 230 psi
 Maximum temperature of fluid: 212°F (100°C)
 High temperature versions available to ... 300°F (149°C)
 Pressure Drop Range:
 0.15 psi (0.01 BAR) to 1.5 psi (0.1 BAR)

Actuator

Material: Housing Aluminum
 Cover Steel
 Finish Polyurethane
 Enclosure NEMA 4
 Supply Pressure 70 psi (5 BAR) to 100 psi (7 BAR)
 145 psi (10 BAR) Max.
 Control Signal 3-15 psi (Pneumatic Positioner)
 4-20 mA (Electro-Pneumatic Positioner)

Standard rotor movement counterclockwise (when viewed from drive end) as temperature increases, clockwise is optional see "Mode of Operation".

OPERATION

The valve uses a spring return pneumatic actuator and positioner to control the rotation of the valve in response to an input signal from a pneumatic or electro-pneumatic control system. The pneumatic control system sends a pneumatic signal ranging from 3 to 15 psi to the actuator to correctly position the valve at the desired temperature setting. The pneumatic control system usually consists of a P+I pneumatic controller, sensor and the necessary air supply conditioning equipment (regulators, filters & water traps).

The electro-pneumatic control system uses a PID electronic controller, RTD sensor and transducer to correctly position the valve. The RTD sensor monitors the actual temperature and feeds the information to the PID controller. The PID controller sends a signal between 4 to 20mA through the transducer to the valve. The transducer, called an I/P ("I to P") converts the 4 to 20mA signal to the 3 to 15 psi that is needed to correctly position the pneumatic valve.

The all pneumatic system has the advantages of not requiring any electrical power. The all pneumatic system usually can be installed in hazardous and corrosive environments without the special requirements needed when using an electronic system.

The electro-pneumatic system has the advantages of having excellent read outs of actual temperature and set point. The set point can easily be changed on the controller. The electronic controller will also have more sophisticated features such as locking out or limiting set point changes.

AMOT can provide either the pneumatic or electro-pneumatic control system for the Model GP to meet the application requirements. The valve will also operate with many existing control systems.

MODES OF OPERATION (Valves illustrated in "Cold" Position)

STANDARD

COUNTERCLOCKWISE ROTATION

CLOCKWISE ROTATION

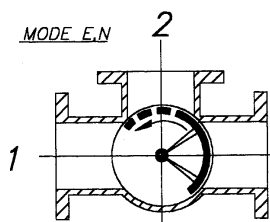

Port 1 - Always open.
 Port 2 - Closed at upper temp.
 Port 3 - Closed at lower temp.

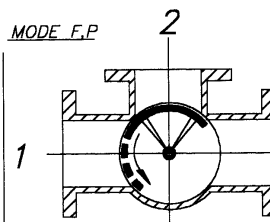

Port 1 - Closed at upper temp.
 Port 2 - Closed at lower temp.
 Port 3 - Always open

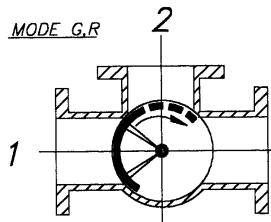

Port 1 - Closed at lower temp.
 Port 2 - Closed at upper temp.
 Port 3 - Always open

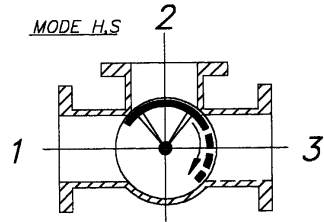

Port 1 - Always open.
 Port 2 - Closed at lower temp.
 Port 3 - Closed at upper temp.

OPTIONAL

COUNTERCLOCKWISE ROTATION

CLOCKWISE ROTATION

MODE J.K

MODE L.M

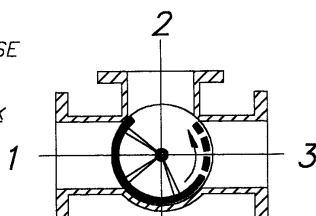

Port 1 - Closed at lower temp.
 Port 2 - Always open.
 Port 3 - Closed at higher temp.

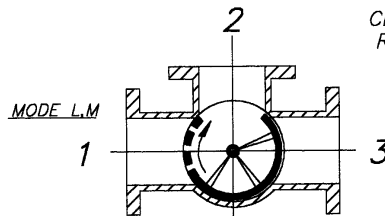

Port 1 - Closed at higher temp.
 Port 2 - Always open
 Port 3 - Closed at lower temp.

MOUNTING

Model GP valves may be mounted in any position. Several modes of operation are possible and it is recommended to choose one that will enable the valve to be mounted in an upright position to facilitate handling and servicing.

INSTALLATION

Model GP valves are typically supported by connecting pipes. Pipework should not be subjected to excessive bending. Line up pipework before tightening the valve flange bolts. If the valve is mounted in a high point in the system, the system should be properly vented to prevent trapping air in the valve body.

VALVE POSITION INDICATION

All GP valves include an indicator of rotor position. The indicator is located on top of the valve positioner.

CONTROL ACCESSORIES

AMOT offers complete control systems for the Model GP Temperature Control Valves. Consult your AMOT Representative for further details of:

Electronic Control Systems
 PID Controller, Model 8061A
 I-P Converter, 4-20mA to 3-15psi, Model 8064A
 RTD Temperature Sensor, Model 8060A

Pneumatic Control Systems
 Liquid-filled capillary type, Model 11598L

AMOT also offers the Model GE Electric Actuated 3-Way Temperature Control Valve. The AMOT Model 8063 Temperature Controller is the matching control system.

VALVE SIZE SELECTION

The internal design of the Model GP creates a low pressure drop. The selection table is based on minimum flow rate at 0.15 psi pressure drop and maximum flow rate at 1.5 psi pressure drop. The valve may be used up to the absolute maximum flow rate; however, internal wear and noise will increase due to the higher velocity.

Model	Cv	Water or Water/Glycol			Lubricating Oil								
		Recommended Range		Absolute Maximum Flow	SAE 10-20 170-550 SSU @ 100°F			SAE 30 550-800 SSU @ 100°F			SAE 40 800-1100 SSU @ 100°F		
		Flow Min.	Flow Max.		Flow Min.	Flow Max.	Absolute Maximum Flow	Flow Min.	Flow Max.	Absolute Maximum Flow	Flow Min.	Flow Max.	Absolute Maximum Flow
		Flow Min.	Flow Max.	Absolute Maximum Flow	Flow Min.	Flow Max.	Absolute Maximum Flow	Flow Min.	Flow Max.	Absolute Maximum Flow	Flow Min.	Flow Max.	Absolute Maximum Flow
2GP	97	37	120	144	35	110	144	30	95	125	25	90	120
3GP	239	90	300	330	85	275	330	75	240	286	70	225	275
4GP	373	145	455	575	135	430	575	117	370	501	110	355	485
6GP	838	325	1025	1320	305	960	1320	260	835	1145	255	810	1100
8GP	1487	575	1825	2330	540	1710	2330	465	1480	2020	450	1435	1950
10GP	2325	900	2850	3425	845	2670	3425	730	2315	2970	705	2245	2875
12GP	3352	1300	4100	5235	1215	3850	5235	1050	3330	4535	1020	3230	4400
14GP	4565	1765	5600	7140	1655	5230	7140	1430	4535	6185	1390	4400	6000
16GP	5956	2305	7300	7780	2160	6830	7780	1870	5925	6740	1815	5740	6535

MODEL CODING SYSTEM

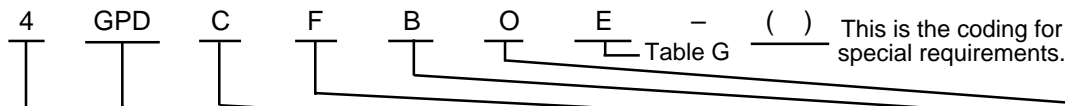

Table A Valve Size		Table B Valve Type		Table C Material				Table D Flange Drilling			Table E Control Signal		
inches	(mm)			Code	Body	Seal	Shaft/Rotor	Code			Code		
2	(50)	GPD	Pneu- matic	B	Bronze	Buna N	SS/Bronze	F	ANSI 125 FF	B	3-15 psi		
3	(80)			C	Cast Iron	Buna N	SS/Bronze	J	ANSI 150 RF			E	4-20 mA
4	(100)			D	Ductile Iron	Buna N	SS/Bronze	B	AMOT Metric 2 (ND 10)				
6	(150)			R	Stainless Steel	Buna N	SS/SS	C	AMOT Metric 3 (ND 16)				
8	(200)			S	Steel	Buna N	SS/SS						
10	(250)			E	Bronze	Viton	SS/Bronze						
12	(300)			F	Cast Iron	Viton	SS/Bronze						
14	(350)			G	Ductile Iron	Viton	SS/Bronze						
16	(400)	H	Steel	Viton	SS/SS								
		J	Stainless Steel	Viton	SS/SS								

Table F
0

Table G Valve Operation Code			
Code	Rotation Mode		System Action
E	Counter clockwise	Port 3 to Port 2	Direct
N	Counter clockwise	Port 3 to Port 2	Reverse
F	Counter clockwise	Port 2 to Port 1	Direct
P	Counter clockwise	Port 2 to Port 1	Reverse
J	Clockwise	Port 3 to Port 1	Direct
K	Clockwise	Port 3 to Port 1	Reverse
G	Clockwise	Port 1 to Port 2	Direct
R	Clockwise	Port 1 to Port 2	Reverse
H	Clockwise	Port 2 to Port 3	Direct
S	Clockwise	Port 2 to Port 3	Reverse
L	Counter clockwise	Port 1 to Port 3	Direct
M	Counter clockwise	Port 1 to Port 3	Reverse

☐ = Non Standard Versions

NOTE: Definition of system action
 Direct: 3 psi (cold) - 15 psi (hot) Reverse: 15 psi (cold) 3 psi (hot)

VALVE DIMENSIONS

VALVE SIZE INCHES (MM)									
Dimension	2 (50)	3 (80)	4 (100)	6 (150)	8 (200)	10 (250)	12 (3000)	14 (350)	16 (400)
A	7.78 (198)	9.45 (240)	10.24 (260)	12.56 (319)	15.63 (397)	18.47 (469)	22.60 (574)	24.57 (624)	27.80 (706)
C & D	4.53 (115)	5.51 (140)	5.91 (150)	7.28 (185)	8.86 (225)	10.24 (260)	11.81 (300)	13.37 (340)	15.16 (385)
E	9.06 (230)	11.02 (280)	11.81 (300)	14.57 (370)	17.72 (450)	20.47 (520)	23.62 (600)	26.77 (680)	30.32 (770)
F	15.95 (405)	17.32 (440)	22.05 (560)	28.15 (715)	31.10 (790)	34.06 (865)	42.91 (1090)	45.87 (1165)	50.59 (1285)
H	3.24 (82)	3.94 (100)	4.96 (126)	6.85 (174)	8.35 (212)	9.92 (252)	11.69 (297)	13.35 (339)	14.88 (378)
APPROXIMATE WEIGHT IN POUNDS (Kg)									
Cast Iron	49 (22)	72 (33)	83 (38)	193 (88)	328 (149)	420 (191)	663 (301)	977 (443)	1292 (586)
Bronze	54 (24)	79 (36)	99 (45)	225 (102)	368 (167)	470 (213)	717 (325)	1089 (494)	1507 (684)
Steel	65 (29)	95 (43)	110 (50)	250 (113)	440 (220)	560 (254)	880 (399)	1300 (590)	1800 (816)

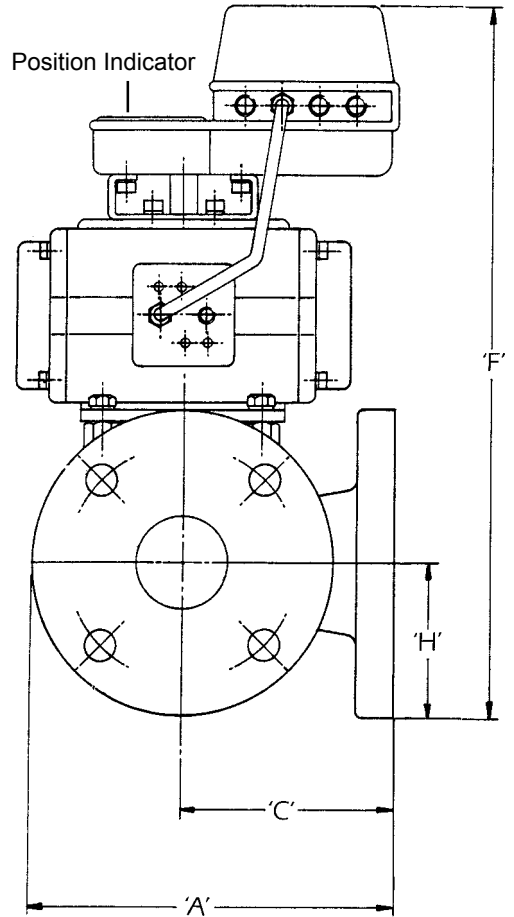

TYPICAL INSTALLATION

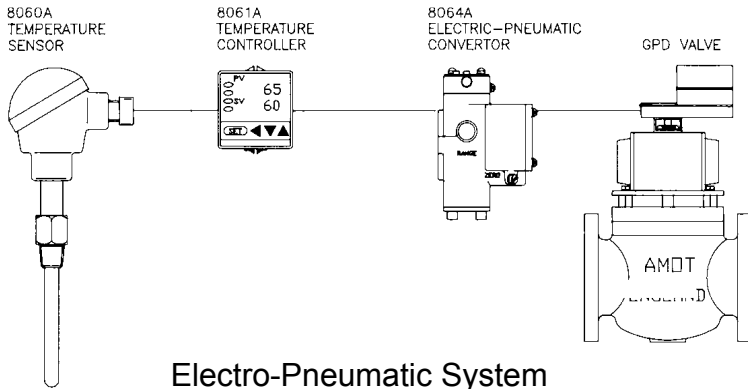

LEAKAGE RATE

Non-contact metal to metal rotor seats require no maintenance. Close tolerances limit leakage.

Size	Leakage Rate C_v	Max. Leakage in GPM
2G	0.6	$Q = C_v \sqrt{\Delta P}$
3G	1.0	
4G	1.9	$Q =$ Leakage in GPM $C_v =$ Flow Coefficient $\Delta P =$ Differential Pressure in psi
6G	3.4	
8G	4.9	
10G	6.2	
12G	8.8	
14G	11.1	
16G	14.1	

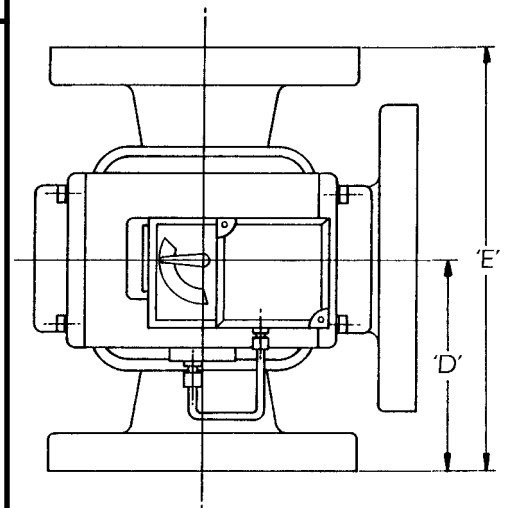

AMOT USA
 401 First Street
 Richmond, CA 94801
 Tel: +1 510 236-8300
 Fax: +1 510 234-9950

AMOT
 Western Way
 Bury St. Edmunds IP33 3SZ
 Suffolk England
 Tel: +44 1284 762222
 Fax: +44 1284 760256

AMOT SINGAPORE
 10 Eunos Road 8 # 12-06
 Singapore Post Centre
 Singapore 408600
 Tel: +65 6293 4320
 Fax: +65 6293 3307