

# **vLocDM User Handbook**

(English Edition)

Version 2.1









# Table of Content

<b>1.</b>	<b>General Safety &amp; Care Information</b>	<b>1</b>
1.1	Who Can Use this Equipment	1
1.2	Work-site Safety	1
1.3	Equipment Safety	1
1.4	Batteries and Environmental Safety	1
1.4.1	Alkaline Batteries	1
1.4.2	Rechargeable Batteries Nickel Metal Hydride and/or Lithium Ion	2
1.4.3	Lithium Metal Batteries (non rechargeable)	2
1.4.4	General Rules regarding Disposal of Batteries	2
1.4.5	Transportation of Lithium Ion and Lithium Metal Batteries	2
1.5	Care and Maintenance of Equipment	3
1.6	Care When Interpreting the Information Provided by the Locator	3
1.7	American & Canadian Safety Notices	3
1.7.1	USA	3
1.7.2	CANADA	3
1.7.3	EUROPE	3
<b>2.</b>	<b>Service &amp; Support</b>	<b>4</b>
2.1	Serial Number and Software Revision Number	4
2.2	Distributors and Service Centers Closest to You	5
<b>3.</b>	<b>Introduction</b>	<b>6</b>
3.1	About this Handbook	6
3.2	Overview of the vLocDM System	6
3.3	Planning a Survey	7
<b>4.</b>	<b>Transmitter Functions and Operations</b>	<b>8</b>
4.1	Transmitter Control Panel	8
4.2	Display	8
4.3	Power Supplies and Connections	8
4.4	Connecting to the Pipeline	9
4.4.1	Connecting at a CP (Cathodic Protection) Station	9
4.4.2	Connecting to the Pipe when there is No Access to a CP Station	10
4.4.2.1	Sacrificial Anode	10
4.4.2.2	Connecting at a Point where Access to the Pipe is Possible	10
4.5	Selecting the Correct Frequency	11
4.6	Output Current Select	11

4.7	Alarms	12
4.7.1	Over Voltage	12
4.7.2	Over Temperature	12
4.7.3	Over Power	12
<b>5.</b>	<b>Receiver Functions and Operations</b>	<b>13</b>
5.1	LCD Features	13
5.2	Pushbutton	14
5.3	Connectors	16
5.4	Batteries	17
5.4.1	Charging Internal Batteries	17
5.5	Setting User Preferences	17
5.6	Setting Frequency Options	18
5.7	Setting Locate Mode	19
<b>6.</b>	<b>Using the vLocDM Receiver</b>	<b>21</b>
6.1	Locating a Pipeline	21
6.2	Pinpointing	22
6.3	Taking Depth and Current Readings	23
6.4	Storing the Results	24
6.5	Graphing the Results	24
6.6	Using the A-frame Fault Finder	26
6.6.1	Fault Finding Method	27
6.6.2	Using the A-frame	27
6.6.3	Using the A-frame where there are Many Defects Such As Porous Coating	29
<b>7.</b>	<b>Using an External GPS Data Logger</b>	<b>31</b>
7.1	Compatible GPS and GPS Data Loggers	31
7.2	Transferring Data to a PC	31
<b>8.</b>	<b>Interpreting Results</b>	<b>32</b>
8.1	Introduction	32
8.2	Sources of Error	32
8.2.1	Operator Error	32
8.2.2	Interference (Distorted Fields)	32
8.2.2.1	Source of Interference (Distorted Fileds)	32
8.2.2.2	Checking for Distorted Fields	33
8.3	Downloading Data to a PC	34
8.4	Interpreting Graphs	38
<b>9.</b>	<b>Care and Maintenance</b>	<b>39</b>
9.1	Cleaning	39
9.2	Checking Functionality	39
<b>10.</b>	<b>Data Sheet</b>	<b>40</b>
<b>11.</b>	<b>Glossary</b>	<b>46</b>
	<b>Notes</b>	

# General Safety & Care Information

## 1.1 Who Can Use This Equipment?

- This equipment must only be used by people suitably trained in the use of pipe and cable locators.

## 1.2 Work-site Safety

- Use your companies, or other applicable safety codes and rules when using this equipment.
- Unless having the required authorization, license and appropriate training – **DO NOT** make connections to any pipe, cable or conductor.
- **DO NOT** use this equipment in explosive areas – such as in the presence of flammable liquids, gases, heavy dust.
- **DO NOT** directly connect this equipment to cables or pipes that have a potential difference to ground of greater than 35V AC.

## 1.3 Equipment safety

- **DO NOT** open the enclosures (housings) of either the transmitter or receiver.
- Place the ground stake firmly in the ground before connecting the cable from the transmitter.
- **DO NOT** hold any uninsulated portion of the Connection leads & Clips when the transmitter is switched on.

## 1.4 Batteries and Environmental Safety

Vivax-Metrotech products use four types of batteries:

- Alkaline batteries
- Ni-MH (Nickel Metal Hydride) – rechargeable
- Lithium ion batteries – rechargeable
- Lithium metal batteries – (small non rechargeable button cells for “clock” applications)

### 1.4.1 Alkaline Batteries

- When replacing the alkaline batteries – use only the size and type specified – **DO NOT** mix battery types (rechargeable and alkaline).
- **DO NOT** mix partially discharged and fully charged cells in the same battery pack – **DO NOT** mix old with new.
- Never attempt to charge alkaline batteries.

### 1.4.2 Rechargeable Batteries Nickel Metal Hydride and/or Lithium Ion

- When using rechargeable batteries, **use only the correct charging device** supplied or specified by the manufacturer. The battery pack or the battery charger will contain circuitry to manage the charging process – other chargers (even if they have the same connector, polarity, voltage & current rating) will not have the same control circuitry and can cause damage to the product, overheating, and in extreme cases fire or harm to the individual.
- **DO NOT** assume that if the plug fits it is the correct charger – a charger with the correct part number **MUST** be used – just because it is a Vivax-Metrotech charger and the plug fits **DOES NOT** mean it is the correct charger.

## 1 General Safety & Care Information

- Before using for the first time, charge rechargeable batteries for 6 hours. If at any time the rechargeable batteries **DO NOT** last as long as anticipated – discharge fully and then charge for 6 hours.
- Care should be taken when charging batteries – **NEVER** repeatedly recharge batteries (or turn power off & on) without using the instrument. If used with an inverter in a vehicle – charge the product then unplug the charger and **DO NOT** charge again until the rechargeable batteries have been used for at least 10 minutes. Failure to do this could result in the overcharging of the battery which will shorten the life of the battery, and could in some circumstances cause overheating or fire.
- If ever the product becomes hot during the charging process **IMMEDIATELY** unplug the charger and use the rechargeable batteries for at least 10 minutes before recharging. If this reoccurs the next time the unit is charged – return immediately to Vivax-Metrotech for repair.
- Lithium Ion Batteries – some products use Lithium ion batteries – the requirements for marking and transportation are still developing. Please contact Vivax-Metrotech before shipping products containing Lithium ion batteries or Lithium ion battery packs on their own for any “special instructions”.
- **DO NOT** charge batteries for prolonged periods of time without using the locator for at least 10 minutes. Charging for prolonged period of time could overcharge the battery, reduce the battery life and in extreme circumstances cause damage to the locator and fire.

### 1.4.3 Lithium Metal Batteries (non rechargeable)

- Commonly known as “button cells” these are small – non rechargeable batteries used to power internal “clocks” within some units (similar to computers). Generally they have a life of 3 - 5 years.
- Under no circumstances should any attempt be made to charge these batteries.
- Dispose of according to your company’s work practice/environmental standards, the prevailing laws, or recognized best practice. Always dispose of batteries responsibly.

### 1.4.4 General Rules regarding Disposal of Batteries

- **NEVER** disassemble a battery, or battery pack.
- Never dispose of in fire or water.
- Dispose of batteries in accordance with your Company’s work practice/environmental standards, the prevailing laws, or recognized best practice. Always dispose of batteries responsibly.

### 1.4.5 Transportation of Lithium Ion and Lithium Metal Batteries

- The Lithium ion and Lithium metal batteries used in Vivax-Metrotech products meet the required safety standards and include the designated protection circuitry.
- Recent regulation changes require that when batteries with Lithium ion and Lithium metal batteries are transported the packaging **MUST** include specified warning labels.

**Please contact Vivax-Metrotech Customer Service (USA 1-800-446-3392 – international +1-408-734-1400 (USA Pacific Time Zone) for more details.**

- Regulations have also changed regarding the shipping of spare battery packs (battery packs that are not inside a product). There are limitations on the weight of the package, and the packaging must be marked with the appropriate warning labels.

**Please contact Vivax-Metrotech Customer Service (USA 1-800-446-3392 – international +1-408-734-1400 (USA Pacific Time Zone) for more details.**



#### **WARNING**

**Remember – Batteries Contain Dangerous Chemicals**

**They can be affected by many things such as water ingress or heat. In some circumstances, they can explode, they also can cause electric shocks!**

## 1 General Safety & Care Information

### 1.5 **Care and Maintenance of Equipment**

- Use equipment only as directed in this User Handbook.
- **DO NOT** immerse any part of this equipment in water.
- Store in a dry place.
- Keep equipment in the case provided when not in use.
- If left for prolonged period of time – remove alkaline batteries.
- Keep unit clean and free of dust and dirt.
- Protect against excessive heat.

### 1.6 **Care When Interpreting the Information Provided by the Locator**

- Like all locators – this instrument is locating, and providing depth and current readings based on electromagnetic signals that radiate from the buried cable or pipe. In most cases these signals will enable the locator to pinpoint both position depth and current correctly.
- **BEWARE** – in some cases other factors will distort electromagnetic fields radiating from cable or pipe being located, resulting in incorrect information.
- Always locate responsibly, and use information learned during your training to interpret the information provided by the locator.
- **DO NOT** provides information regarding depth of cable or pipe to anyone unless authorized to do so by your company.
- **REMEMBER** that depth measurements are to the center of the electromagnetic field or pipe – In the case of pipes this may be significantly deeper than the top of the pipe.

### 1.7 **American & Canadian Safety Notices**

#### 1.7.1 **USA**

- This transmitter and receiver comply with the general conditions of operation, pursuant to part 15 of the FCC Rules.
  - CFR 47 Part 2 : 2004
  - CFR 47 Part 15 : 2006
  - ANSI C63.4 : 2003
- Changes or modifications not expressly approved by the manufacturer could void the user's authority to operate the products.

#### 1.7.2 **CANADA**

- Equipment is for use by trained operators only, and not for general household or consumer use.
- Usage duration shall be as short as possible; to prevent possible radio interference to authorized services, especially the 100 kHz Loran-C frequency.
- Operation is subject to the following two conditions: (1) this device may not cause interference, and (2) this device must accept any interference that may cause undesired operation of the device.

#### 1.7.3 **EUROPE**

- Vivax-Metrotech confirms that the location system is compliant with relevant provision of European directive 1999/5/EC.
  - ETSI EN 300 330-2 : 2006
  - ETSI EN 301 489-1 : 2005
  - ETSI EN 301 489-3 : 2002

## Service & Support

### 2.1 Serial Number and Software Revision Number

Always quote your receiver and transmitter model and serial numbers and software revision number when requesting product support. They can be found as follows: (for reference only)

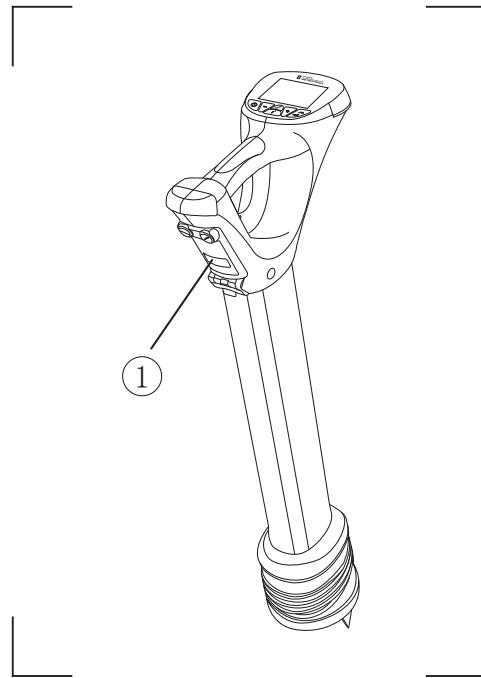
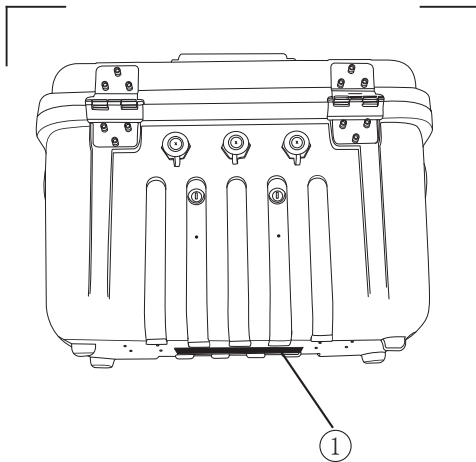

Note:  
The transmitter Serial # and Model # can be found at the bottom of the transmitter.  
On both receiver and transmitter, the software revision is displayed on the LCD during the start up sequence.

1	Model # and Serial #
---	----------------------

## 2 Service & Support

### 2.2 Distributors and Service Centers Closest to You:

#### **United State of America**

##### **Vivax-Metrotech Corporation**

3251 Olcott Street,  
Santa Clara, CA 95054, USA  
Website : [www.vivax-metrotech.com](http://www.vivax-metrotech.com)

##### **Sales & Sales Support:**

T/Free : +1-800-446-3392  
Tel : +1-408-734-1400  
Fax : +1-408-734-1415  
Email : [sales@vxmt.com](mailto:sales@vxmt.com)

##### **Application Support:**

T/Free : +1-800-624-6210  
Tel : +1-408-454-7159  
Fax : +1-408-743-5597  
Email : [applications@vxmt.com](mailto:applications@vxmt.com)

##### **Service & Repairs:**

T/Free : +1-800-638-7682  
Tel : +1-408-962-9990  
Fax : +1-408-734-1799  
Email : [service@vxmt.com](mailto:service@vxmt.com)

##### **All Other Department:**

T/Free : +1-877-330-1647  
Tel : +1-408-734-3880  
Fax : +1-408-962-9993

#### **Canada**

##### **Vivax Canada Inc.**

400 Esna Park Drive,  
Unit 17, Markham,  
Ontario, L3R 3K2, Canada

Tel : +1-289-846-3010  
Website : [www.vivax-metrotech.com](http://www.vivax-metrotech.com)  
Email : [CanadianSales@vxmt.com](mailto:CanadianSales@vxmt.com)

#### **Europe**

##### **SebaKMT**

Seba Dynatronic  
Mess-und Ortungstechnik GmbH  
Dr.-Herbert-lann-Str. 6,  
96148 Baunach, Germany

Tel : +49-9544-680  
Fax : +49-9544-2273  
Website : [www.sebakmt.com](http://www.sebakmt.com)  
Email : [service@sebakmt.com](mailto:service@sebakmt.com)

#### **Australasia**

##### **SebaKMT AUS**

Unit 1, 176 South Creek Road,  
Cromer NSW 2009, Australia

Tel : +61-2-9972-9244  
Fax : +61-2-9972-9433  
Website : [www.sebakmtaus.com](http://www.sebakmtaus.com)  
Email : [sales@sebakmtaus.com](mailto:sales@sebakmtaus.com)  
[service@sebakmtaus.com](mailto:service@sebakmtaus.com)

#### **China**

##### **Leidi Utility Supply (Shanghai) Ltd.**

Rm405 3<sup>rd</sup> Building No. 641, Tianshan Rd,  
Shanghai, China 200336

Tel : +86-21-5187-3880  
Fax : +86-21-5168-5880  
Website : [www.leidi.com](http://www.leidi.com)  
Email : [info@leidi.cn](mailto:info@leidi.cn)

# Introduction

## 3.1 About this Handbook

This handbook is designed to provide the user with a comprehensive understanding of the operation of the vLocDM system. The handbook assumes some understanding of Cathodic Protection techniques, it covers the operation of the equipment, the techniques to gather data, storing and retrieving the data in a format that can be analyzed by a competent engineer and a brief explanation of how to use the data to form an understanding of the condition of the pipe network.

## 3.2 Overview of vLocDM System

The vLocDM (Defect Mapper) has been designed to:

- identify the position of coating defects
- identify shorts to other structures
- help categorize the faults
- help plan and prioritize remedial work

The vLocDM uses the latest locating and signal processing techniques to plot the current gradient of an industry standard low frequency (3Hz) profiling current. The current is typically applied at CP stations so the disruption of the pipeline can be minimized.

The Loc-150Tx, 150W transmitter (vLocDM transmitter) is used to apply a signal current to the anode bed. The pipeline returns the signal via coating faults back to the transmitter. The transmitter is designed to be powered from CP (Cathodic Protection) stations, AC or external batteries, eliminating the need for batteries.

The non-intrusive measuring device, the vLocDM receiver, takes measurements along the pipeline and plots the results directly onto the screen of the receiver. There is no need to carry extra logging and display devices. All the data is displayed and logged into the receiver and can be downloaded to a spread sheet or dedicated analysis program such as Spectrum XLI™ or similar.

A +/- 3m accuracy GPS antenna is included with the system. It links to the vLocDM receiver via Bluetooth radio link. The GPS enables the user to generate real time current gradient graphs and guides the user back to a point of interest by highlighting the user's position on the graph. This feature is called the "walk back" feature. The system can also be integrated with high accuracy GPS systems and software packages, for example Trimble and TriGlobal Inc.

Storing the results also has the benefit of facilitating the technique of comparative tests. Comparing the results from previous surveys of the same length of pipe allows the CP engineer to establish trends of coating deterioration.

The A-frame fault finding accessory is used to accurately locate the position of a fault. An arrow points the user to the position of the fault whilst quickly and efficiently graphing the characteristic shape and magnitude of fault signal on the receiver's display. This ensures the user minimizes the chances of misidentification.

### 3.3 Planning a Survey

Surveys will vary greatly depending on type of terrain, accessibility, condition of pipeline, type of pipeline and coating type.

The first step of undertaking any survey should be to obtain information about the stretch of pipeline to be surveyed. More work at this stage may well save time and effort later. Obtaining maps showing route information, CP stations, sacrificial anodes and cross bonding points will be of great help.

The transmitter should be capable of transmitting from one CP station to another, so although not absolutely necessary, plan to have the previous and after CP stations disconnected from the stretch of pipeline to be surveyed. Remember that the pipeline is not protected whilst the survey is being undertaken, so unnecessary downtime of CP stations should be avoided.

Choose the survey interval to match the condition of the pipeline. In areas where the coating is particularly poor, a survey interval of as little as 10m may be desirable. However, if the coating is in very good condition and the distance between CP stations is many km, it may be better to choose a survey interval of as much as 200m. Taking measurements at large intervals will enable the surveyor to quickly assess the condition of the pipeline and subsequently identify areas that require further inspection at closer survey intervals or detailed analysis using the A-frame Fault Finder accessory.



**WARNING**

**Parts of the pipeline may be crossing road junctions and may even follow the route of roads. Obtaining accurate results from the vLocDM requires full concentration from the operator. It is therefore essential that correct traffic management is undertaken at these points to avoid poor results or injury to the operator. Safety should always be the first concern.**

# Transmitter Functions and Operations

## 4.1 Transmitter Control Panel

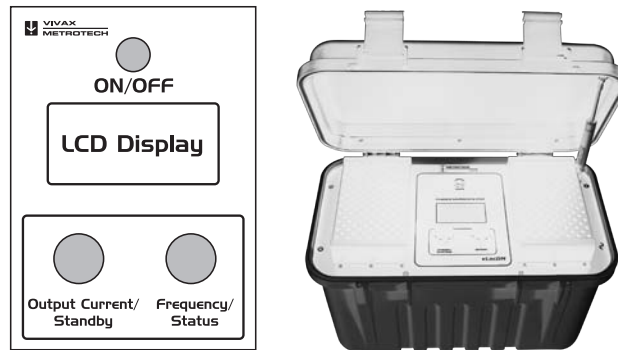

## 4.2 Display



## 4.3 Power Supplies and Connections



1	Mains Input
2	Mains Input Fuse
3	12-60V DC Input
4	Output Fuse
5	Output Socket

## 4.4 Connecting to the Pipeline

### 4.4.1 Connecting at a CP (Cathodic Protection) Station



**WARNING**

Connecting to the CP station involves removing connections from the CP transformer rectifier and should only be performed by authorised personnel. Always make connections before switching on the unit. Switch off before disconnecting the transmitter.

**Method:**

1. Make a note of the CP settings (Output Current and Voltage settings). This is important as the settings must be checked to ensure they return to the original settings when the connections are re-made.
2. Switch off the CP transformer rectifier and allow the residual voltage to dissipate. This may be a few seconds or a few minutes depending on pipe condition.

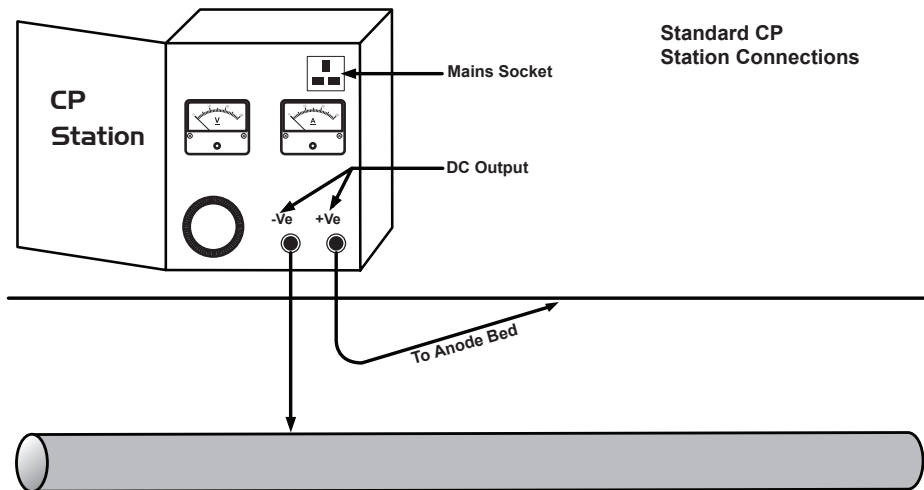

3. Disconnect the output wires connecting the CP station to the pipeline and anode bed. If there is an earthed mains socket at the station, connect the transmitter mains power lead to the socket.

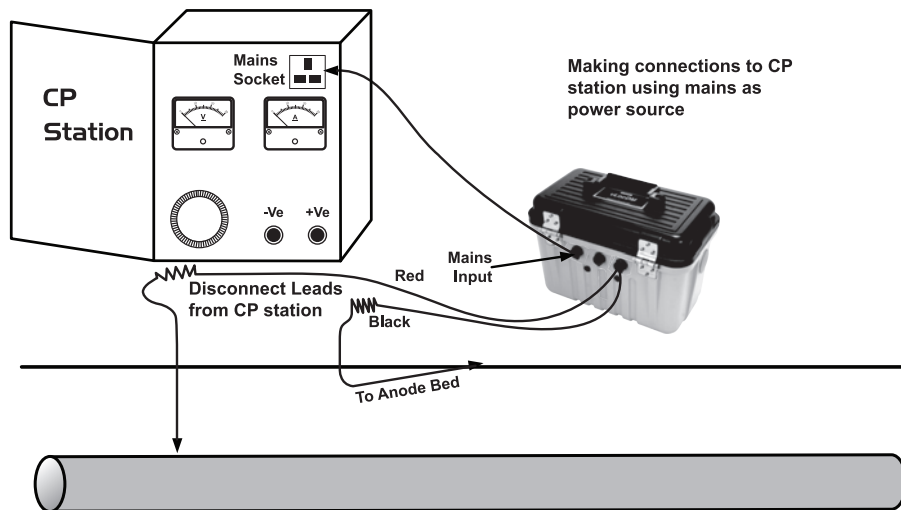

## 4 Transmitter Functions and Operations

4. If there is no mains socket, it is possible to use the DC output of the transformer rectifier. See diagram below.

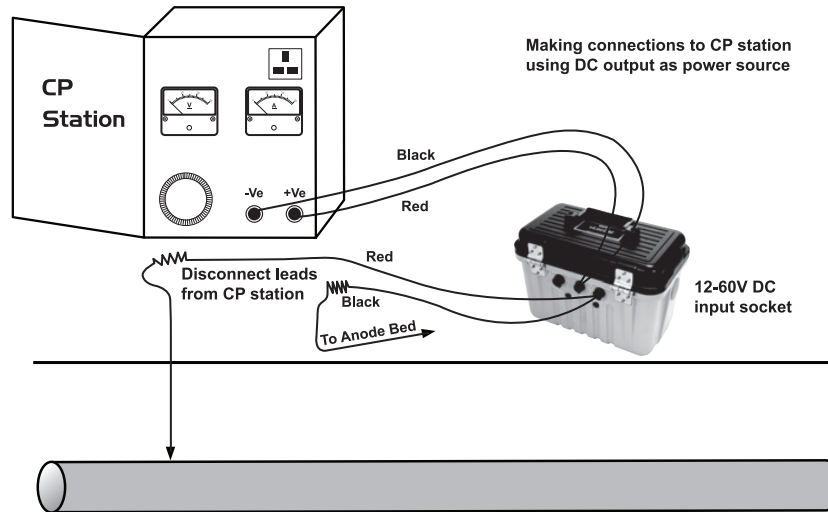

5. Adjust the transformer output to approximately 40V DC (although the unit will function from 12V DC to 60V DC) and use the DC input lead to connect the transmitter to the transformer terminals.
6. With the output lead connected to the transmitter, connect the Red wire to the lead connecting to the pipeline. Connect the Black wire to the lead connecting to the anode bed. See diagram above.



### NOTE

If the output leads are white and green, the white cable should be connected to the pipe.

### 4.4.2 Connecting to the Pipe when there is No Access to a CP Station

#### 4.4.2.1 Sacrificial Anode

Very often the cable connecting a sacrificial anode to a pipe is fed through an above ground connection box. If this is the case the anode can be disconnected and these cables used to connect the transmitter to the pipe. The Red connection lead needs to be connected to the pipe side and the Black to the sacrificial anode.

It will be necessary to power the transmitter either from a portable 110V AC mains generator, or from a vehicle car battery or external 12V DC power source.



### NOTE

It may not be possible to attain high current from the transmitter, as a sacrificial anode will not provide as good a ground as a system anode bed.

#### 4.4.2.2 Connecting at a Point where Access to the Pipe is Possible

It is possible to connect the transmitter at any point along the pipe length where an electrical connection is possible. If this is the case a good independent ground will need to be generated by driving a ground stake into the ground a few meters perpendicular to the pipe. The ground needs to be low impedance so the copper ground rod needs to be at least 0.5 meters long. In some cases multiple stakes may be necessary.

A poor ground will result in the transmitter showing the over voltage alarm even at low currents. If this occurs add further ground rods connected in parallel and dampen the surrounding soil.

## 4 Transmitter Functions and Operations



### WARNING

Use a cable locator to ensure the area is clear of services before the rod is driven into the ground.

### 4.5 Selecting the Correct Frequency

The available frequency options are:

- 98Hz, 128Hz, 512Hz, 640Hz, 3Hz/98Hz, 3Hz/128Hz, 4Hz/98Hz
- 4Hz/128Hz
- ELF1-3Hz/6Hz/98Hz
- ELF2-3Hz/6Hz/128Hz
- ELF3-4Hz/8Hz/98Hz
- ELF4-4Hz/8Hz/128Hz
- 3Hz/6Hz/512Hz
- 3Hz/6Hz/640Hz
- 4Hz/8Hz/512Hz
- 4Hz/8Hz/640Hz

3Hz/6Hz/98Hz or 3Hz/6Hz/128Hz are the most commonly used frequencies. They provide the low frequency 3Hz component required for current mapping and a low frequency (98Hz or 128Hz depending on local mains frequencies) used to pinpoint the position and is used to determine the pipe depth. The 6Hz enables the locator to calculate the signal direction.

The other frequency options can be used to improve reception in areas of high interference.

### 4.6 Output Current Select

There are seven current settings:

- 100mA
- 300mA
- 600mA
- 1A
- 2A
- 3A
- 4A (When a single locate frequency is selected)

Choosing the correct setting for a particular application depends on many factors but as a general rule “the higher the setting the better”. The higher the current the more stable the readings at long distance and larger currents create larger current changes at faults. However, it will not always be possible or desirable to apply the maximum current.

With the transmitter connected as above, select the 3A position. Wait to see if any alarms are displayed such as over voltage, over power, over temperature. If after 20 seconds no alarms are shown, note the return current reading. This should be 3A+/- 0.1A. Now note the output voltage. This should be less than 100V. The transmitter stabilises the output current by altering the output voltage. The output voltage limit is 100V. If the current cannot be stabilised with a voltage less than 100V it will display an overvoltage alarm. The transmitter is not damaged if this is displayed but the output will not be stabilised. To overcome this, select a lower current setting.

## 4 Transmitter Functions and Operations

Other causes of overvoltage alarms are:

- Pipeline in very good condition (Small high impedance faults will require higher voltages to achieve the requested current)
- Poor anode bed (Poor anode beds will require a high voltage drop across them to create the requested current)
- Poor pipe connections

### **4.7 Alarms**

#### **4.7.1 Over Voltage**

Output exceeds 100V. (Also see Output Current Select)

#### **4.7.2 Over Temperature**

The over temperature alarm will show on the display when the temperature of the output amplifier exceeds a predetermined level. At this temperature the unit will shut down and cannot be switched on until the unit has cooled down.

After the unit has been cooled down, it may be necessary to place the unit in a position where the ambient temperature is less such as shaded position. Alternatively select a lower current output.

#### **4.7.3 Over Power**

The Over Power alarm will be shown on the display when the output power rating of the transmitter is reached. The unit will shut down until the output power is reduced.

This can be done either:

- Reduce the output current setting
- Improve the ground and pipe connections (This may be the case where the ground used is not an anode bed. For instance where a ground rod is used because access to a CP station is not possible.)

# Receiver Functions and Operations

## 5.1 LCD Features

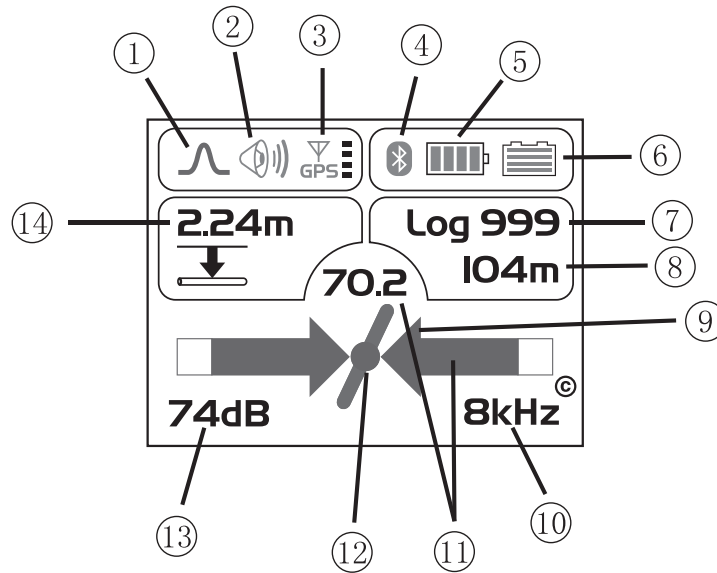

1	Locate Mode	8	Distance From Last Measurement
2	Speaker Status	9	Left/Right Indicator
3	GPS Option Active, bars indicate accuracy	10	Locate Frequency
4	Bluetooth Active	11	Signal Strength
5	External Battery Indicator	12	Pipe Direction Indicator
6	Internal Battery Indicator	13	Gain Setting
7	Last Record Number	14	Depth to Centre of Pipe



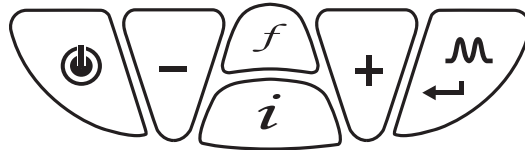



## 5.2 Pushbutton



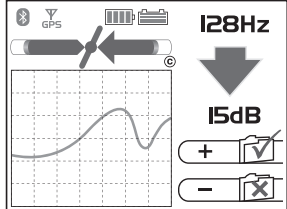
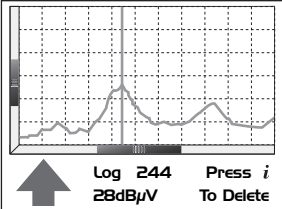



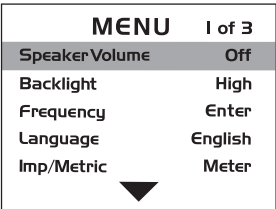

Pushbutton	Locate Screen	Measure Screen
	On/Off	On/Off
	Change frequency	Not active
	Short press for measure and long press for user menu	Jump back to Locate Screen
	Increase gain	Save and go to graph
	Decrease gain	Reject and go to graph and long press to delete log in memory
	Change antenna mode	Save a record and return to Locate Screen

Pushbutton	Graphing Screen	Graph Review
	On/Off	On/Off
	Not active	Not active
	Highlights active graphing button	Deletes highlighted log
	Zoom in (scroll right/up) and long press to auto scale horizontal axis	Moves cursor right and also used to confirm delete
	Zoom out (scroll left/down) and long press to auto scale vertical axis	Moves cursor left
	Return to Locate Screen	Returns to Graphing Screen

## 5 Receiver Functions and Operations

Pushbutton	A-frame Screen	A-frame Review
		
	On/Off	On/Off
	Not active	Not active
	Long press to enter "A-frame Review" mode	Deletes highlighted log
	Save last reading to graph	Moves cursor right and also used to confirm delete
	Short press rejects last record and long press to clear graph.	Moves cursor left
	Return to Locate Screen	Returns to Graphing Screen

Pushbutton	User Menu Screen
	
	On/Off
	Not active
	Return to Locate Screen
	Scroll down
	Scroll up
	Select/ deselect item

### 5.3 Connectors

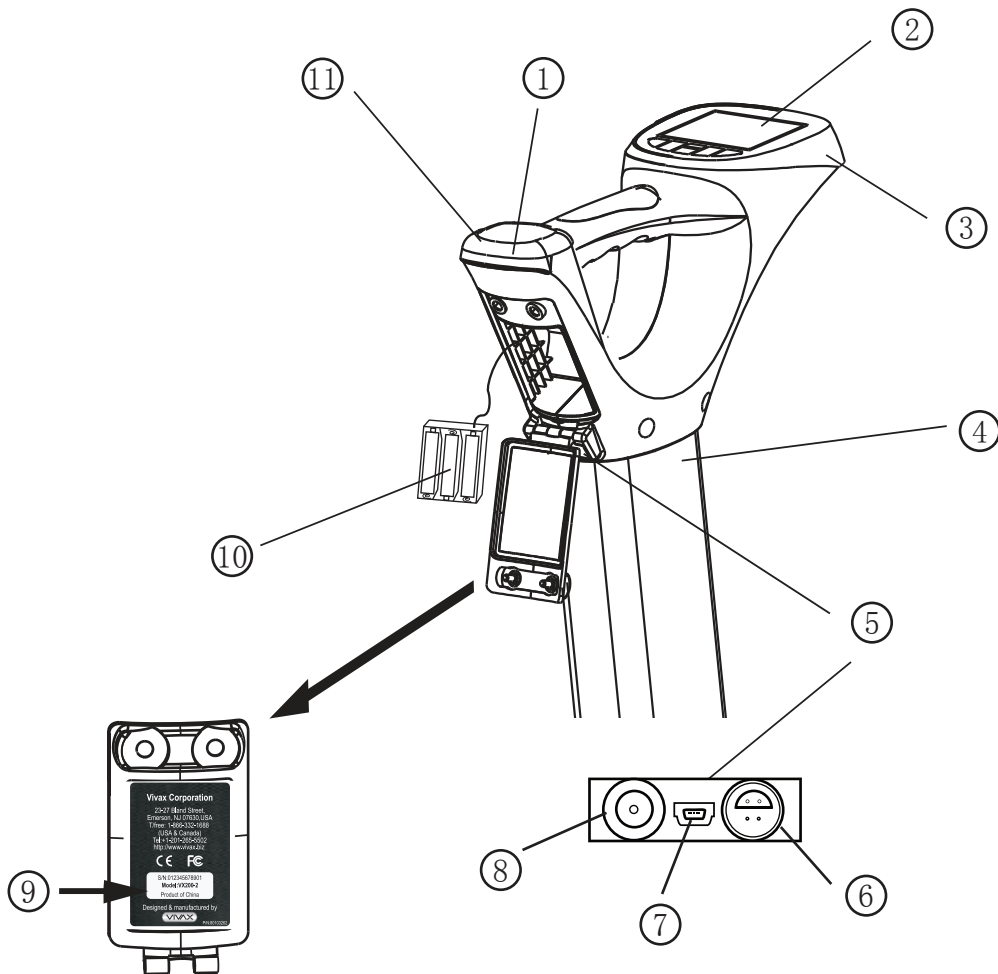

1	Rechargeable Batteries (internal)	7	Mini USB Port
2	Pushbutton & Display	8	Charging Socket
3	Impact Protection	9	Model# & Serial#
4	Carbon Fiber Reinforced Antennal Assembly	10	AA Battery Pack (Removable)
5	Accessory & Charging Sockets	11	Impact Protection
6	Accessories Port		

## 5.4 Batteries

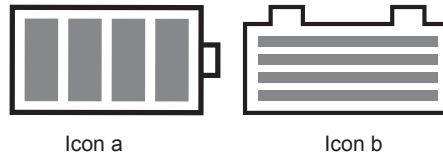

The receiver has two battery packs:

- External alkaline battery pack. Icon “a” indicates the status of the external battery pack.
- Internal rechargeable batteries. Icon “b” indicates the status of the internal battery pack.

The unit will operate from the internal batteries until they have no charge left. The unit will then automatically switch over to the external alkaline batteries when this occurs.

### 5.4.1 Charging Internal Batteries

Connect the supplied battery charger to the charging socket of the receiver and the mains supply. The LED indicator should change from “off” to “red” when the charger is connected. When the batteries are charged, the LED indicator will change from “red” to “green”.

Charge time will vary depending on charge state of batteries but will typically be two hours.

## 5.5 Setting User Preferences

The vLocDM has many functions enabling it to be used for many applications and can be configured for different markets. For instance, it may be desirable for the depth readings to be displayed in imperial measurements or metric. By entering the user menu, it is possible to tailor the vLocDM to the requirements of the user.

Enter the user menu by pressing and holding the “i” pushbutton for approximately two seconds until the user menu is displayed.

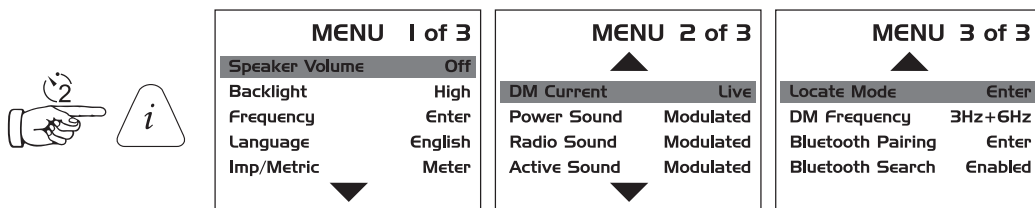

## 5 Receiver Functions and Operations

Select the desired function by pressing the “+” or “-” pushbutton. The active function will be highlighted in red. To change the setting of the selected function, press the “return/↵” pushbutton.

Configurable options are:	Return/↵ Pushbutton	Note:
Speaker Volume	Off, Low, Med, High	
Backlight	Off, Low, High	
Frequency	Enter	Sub menu
Frequency	English	
Imp/Metric	Meter, Feet	
DM Current	Live Static	Live - continuous update of DM current Static - One shot display of DM current per measurement
Power Sound	Normal, Modulated	Normal – the pitch remains the same but the volume increase as the signal increases Modulated – the pitch changes as the signal increases
Active Sound	Normal, Modulated	
Radio Sound	Normal, Modulated	
Locate Mode	Enter	Sub menu
DM Frequency	3+6Hz, 4+8Hz, 3Hz, 4Hz	Selects the DM current measurement
Bluetooth Pairing	Enter	Used to pair the receiver with external device such as external GPS
Bluetooth Search	Enable, Disable	Disable when Bluetooth not in use to improve locate performance.

To ensure maximum use from the battery it is recommended that the speaker volume be set to “Med” and the backlight set to “Low”.

“Frequency” and “Locate Mode” functions are written in green. This is to indicate that there is a sub menu to choose from. To enter the sub menu, press the “return/↵” pushbutton.

To exit to the Locate Screen, press “i” pushbutton.

### 5.6 Setting Frequency Options

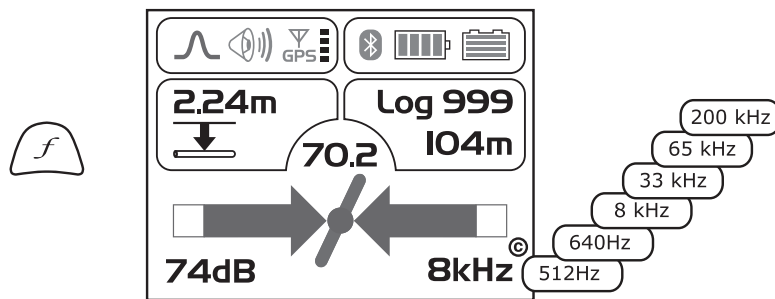

## 5 Receiver Functions and Operations

The receiver is capable of detecting a large number of frequencies. To simplify the operation of the equipment, it is possible to activate only frequently used frequencies. This is done by entering the user menu.

The initial frequencies set at the time the unit is supplied are "Power", "Radio" and the frequencies used by the transmitter purchased. See the transmitter section for suggestions of which frequency is best suited to specific applications.

### Frequency Selection

<input type="radio"/> 380 Hz	<input type="radio"/> 560 Hz
<input type="radio"/> 400 Hz	<input type="radio"/> 577 Hz
<input type="radio"/> 440 Hz	<input type="radio"/> 604 Hz
<input type="radio"/> 484 Hz	<input type="radio"/> 624 Hz
<input checked="" type="radio"/> 512 Hz	<input type="radio"/> 640 Hz

To select the frequencies you wish to use regularly – enter the setup menu by pressing and holding the "i" pushbutton for 2 seconds. Use the "+" and "-" to select the word "Frequency" – then press the "M" mode pushbutton to display the list of available frequencies.

The "+" and "-" pushbuttons are used to navigate the list of frequencies. To add a frequency to the "Frequently used list", press the "Return" pushbutton and a dot will appear in the circle alongside the frequency. To deselect a frequency, press the "Return" pushbutton and the dot will disappear. Once your selection is completed press "i" pushbutton once to return to the setup menu, and again to exit the setup menu.

### 5.7 Setting Locate Mode



### MENU 3 of 3

▲

Locate Mode	Enter
DM Frequency	3Hz+6Hz
Bluetooth Pairing	Enter
Bluetooth Search	Enabled





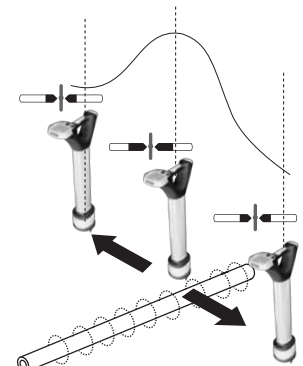

Press and hold the "i" pushbutton to enter the user menu. Use the "+" or "-" pushbutton to navigate to "Locate Mode". Press "return" pushbutton to select sub menu. The following will be displayed:

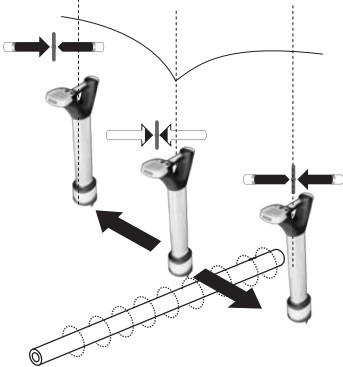

Peak Mode:  
Largest signal over the pipe.

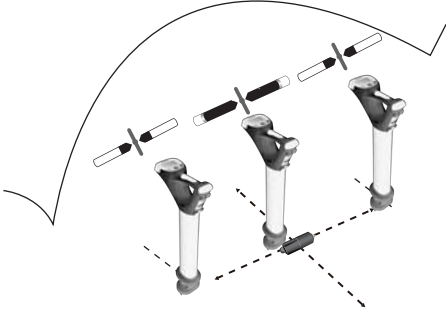

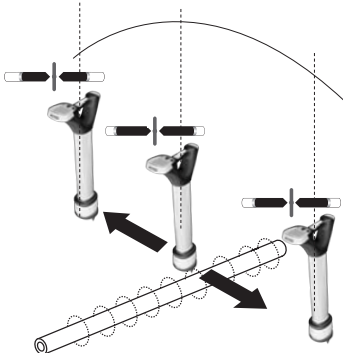
5 Receiver Functions and Operations

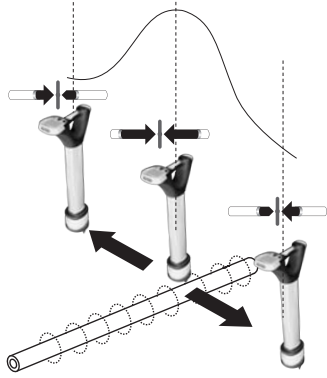
 <p>Null Mode: Minimum signal over the pipe includes left/right guidance arrows.</p>	
 <p>Sonde Mode: Largest signal over the Sonde. Note: Locator is held ACROSS the line of the Sonde. Also note two false signals each side of main signal.</p>	
 <p>Broad Peak Mode: Increased sensitivity but sharpness reduced. Useful for deep pipes.</p>	
 <p>Peak with Arrows Mode: Largest signal over the pipe. Includes left/right guidance arrows.</p>	

Press the "Return" pushbutton to select or deselect a function as indicated by a dot. To exit the user menu, press "I" pushbutton.

## Using the vLocDM Receiver

### 6.1 Locating a Pipeline



**NOTE**

There are a number of antenna configurations available. Each has a particular response. However, for the purposes of simplicity the method below uses the generic “peak with left right arrows”.

Connect the transmitter to the pipeline to be surveyed as instructed in section “Connecting the Transmitter”. Switch on the receiver and select the frequency to match the frequency selection on the transmitter. Stand approximately 10 – 20 meters/yards from the transmitter and over the suspected position of the pipe. Stand facing the transmitter and with the handle and display pointing at the connection point. See diagram below.

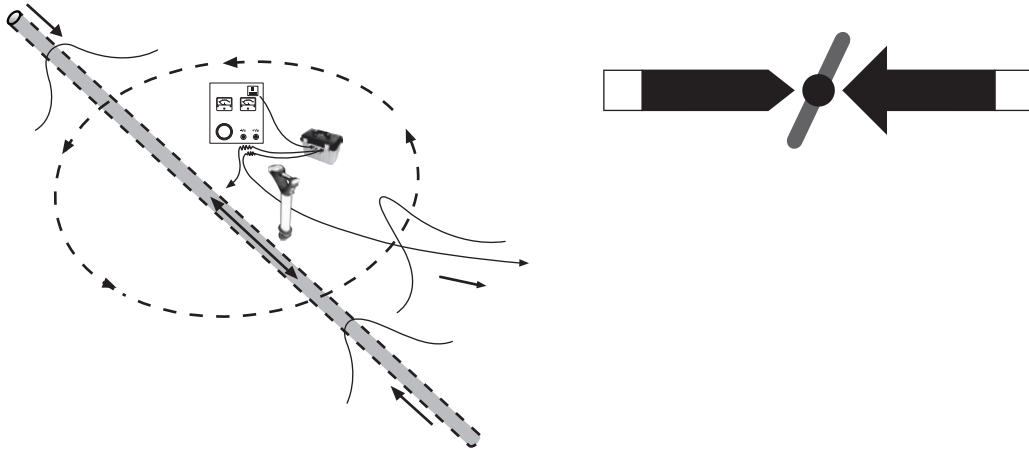

Keeping the receiver pointing at the connection point, walk around the connection point for a full 360 degrees. The reading on the receiver signal strength meter will rise and fall as it passes over:

- the two pipe locations (Forward and Aft)
- the cable running to the anode bed

It will be necessary to adjust the sensitivity of the receiver to keep the signal strength within the signal strength scale. If the signal is very low on the scale, pressing the “+” pushbutton will adjust the gain so that the signal strength is approximately 50% of scale. If the signal goes over the top of the scale press the “-” pushbutton to return it to approximately 50%. Subsequent pressing of the “+” or “-” pushbuttons will increment the gain.

Notice that as the pipe is neared the left/right arrow will point to the position of the pipe and the pipe directions indicator will align itself with the direction of the pipe.

## 6.2 Pinpointing

Before measurements are taken it is necessary to precisely pinpoint the pipeline.

To do this, follow the following steps:

1. Rotate the locator so that the compass line direction indicator is pointing North/South.
2. Move the locator in the direction indicated by the arrow. Stop when the arrow changes to the opposite direction.
3. Adjust the gain by pressing the “+” or “-” pushbuttons so that the bar graph reads approximately 50%.
4. Find the largest signal by moving the receiver side to side over the suspected position of the pipeline, see:
  - (a) Stop at the largest signal. (Note that the left/right arrows will help in this process but the largest bar graph reading gives a truer indication of the actual pipe position.) Now rotate the receiver again until the largest signal is found and the line indicator is pointing at North and South position
  - (b) The receiver is now over and the handle is in line with the pipe.

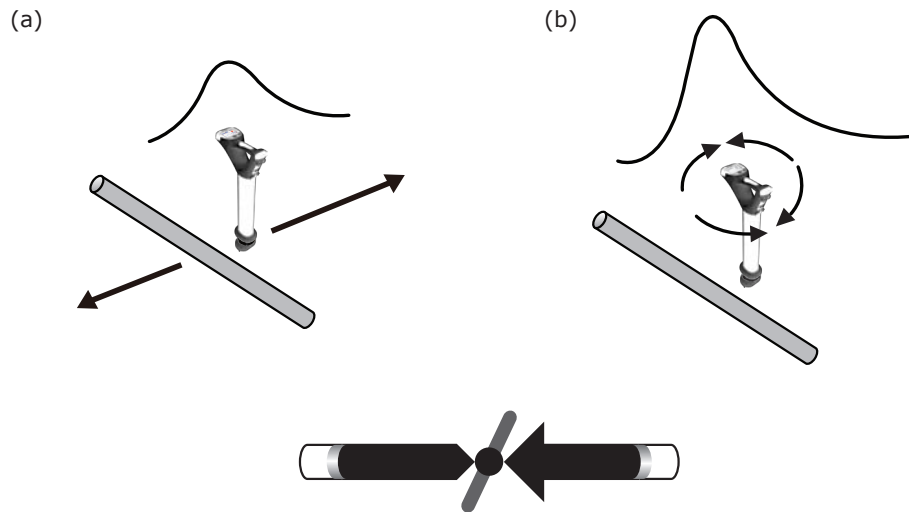

### NOTE



The largest signal and current reading will probably be generated by the anode bed cable. Confirm which is which by taking current readings and noting the current direction. The currents on the pipe will be flowing towards the transmitter. The current on the anode cable will be flowing away.

### NOTE



The sum of the currents on the two pipe locations should be close to the current displayed on the transmitter. If they are not, it may be that there is a fault at the connection point or that the current flowing on the anode bed cable is interfering with the signal from the pipe. To confirm this take readings a good distance from the connection point. Be aware that the anode bed cable very often runs along the same trench as the pipe for some distance and will affect the readings.

### 6.3 Taking Depth and Current Readings

To take any measurements it is first necessary to pinpoint the pipe as instructed in the section above “pinpointing”.

Next, hold the receiver on the ground, vertically and with the handle in line with the pipe. Keep the receiver very stationary and press the “i” pushbutton. The display will show the following screen whilst the measurement is made

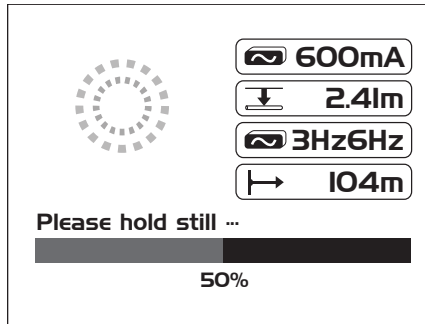

After approximately 4 seconds the result will be displayed as below.

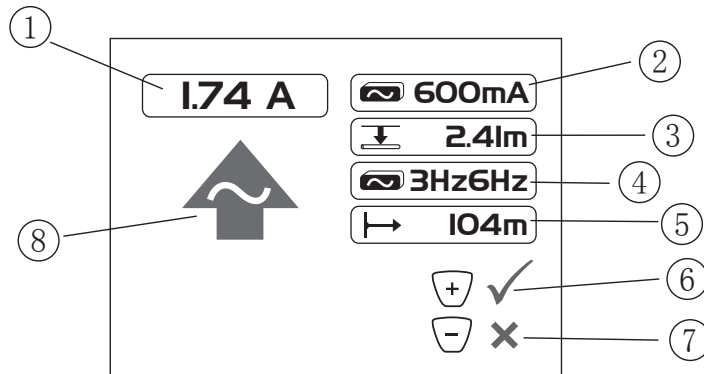

1	vLocDM Mapping Current
2	Locate Tone Current
3	Depth to centre of pipe
4	DM Frequency
5	Distance from last stored measurement if GPS fitted
6	Save reading and enter graph
7	Reject reading and enter graph
8	DM Signal Direction

Press the “Return” pushbutton to save the data and return to “Locate Screen”.

## 6.4 Storing the Results



### NOTE

The DM current reading will continue to be updated approximately every second unless Static is chosen in the User setup of “DM Current”. This is done so that fluctuations in readings can be identified, allowing the user to wait until stable readings are shown before recording the result.

Pressing the “+” pushbutton whilst the measurement is being displayed will save the results to the next available internal log location, plot the point onto the onboard graph and will also transmit the data using the Bluetooth function.

Pressing the “-” pushbutton whilst the measurement is being displayed does the same as the above. But does not add this point to the record or the graph and does not transmit the data.

Pressing and holding the “-” pushbutton clears the internal log memory. Before the log is cleared a message is displayed as shown in the screen below. Press the “+” pushbutton to delete the log or press the “-” pushbutton to return to the locate screen.

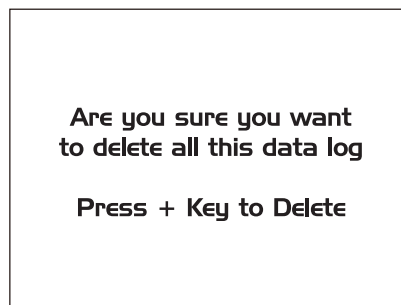

Pressing the “Return” pushbutton whilst the measurement is being displayed will save the results to the next available internal log location, and return to the Locate Screen.

## 6.5 Graphing the Results

Graphing the results can be done with or without the GPS function activated. However, if the GPS function is not activated the generated graph will not be scaled with distance but will space the records equally along the x axis. The “walk back feature” will not function unless the GPS feature is activated. To activate the GPS feature, read section 7.1 Compatible GPS and GPS Data Loggers. To activate the GPS function, see section 7.1.

The GPS icon on the Locate Screen will illuminate when valid GPS data is being received.

Pressing the “+” pushbutton whilst the measurement is being displayed will automatically update the graph and will also enter the graphing screen.

**Graph Screen**

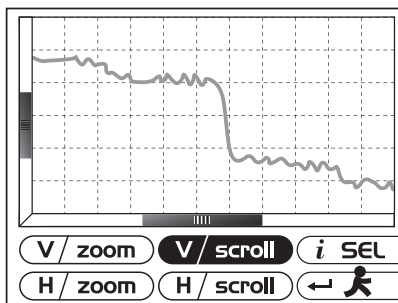

Pushbutton	Function
	Highlight each function in turn. A long press will enter the Review Screen.
	Increase zoom or scrolls right/up depending on button highlighted. Long press auto scale horizontal axis.
	Decrease zoom or scrolls left/down depending on button highlighted. Long press auto scale vertical axis
	Returns to the Locate Screen

To clear the screen, press and hold the “-” pushbutton for 3 seconds. A message will be displayed.



**NOTE**

The horizontal scale of the graph defaults to equal spaces per record. So the graph assumes equal distance survey points.

If GPS is activated, the horizontal axis is based on the “as the crow flies” distance between measurement points (see Section 7.1 Compatible GPS and GPS Data Loggers).

The range finder bars on the x and y axis indicate the portion of graph being viewed.

Pressing and holding the “-” and “+” pushbuttons auto scales the graph in the x and y axis.

If the GPS option is activated, an indicator will be displayed at the present position. This is the “walk back” feature. Use the indicator to identify your position on the graph as you walk back to a point of interest. The indicator will identify the point when it detects that it is within 25m. If the points are closer than 25m, it will show the nearest one. If the distance to any point is greater than 25m, no indicator is shown.

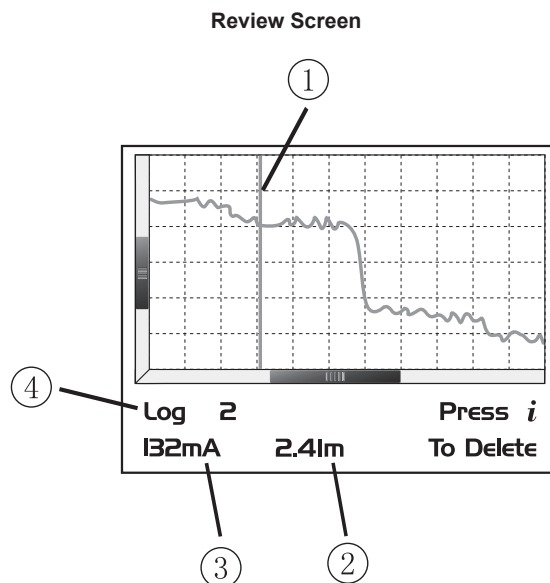

1	Position Indicator Bar
2	Depth to centre of pipe at this point
3	DM current reading at this point
4	Record number as indicated by position indicator bar

When in the Graphing Screen, pressing and holding the “i” pushbutton enters into the Review Screen. This enables the user to scroll through the logged points. A blue vertical line identifies the log position. At each position, the depth and DM current readings are shown at the bottom of the graph. To delete a record, press the “i” pushbutton. The unit will ask the user to confirm by pressing the “+” pushbutton.

To return to the Graph Screen press the “Return” pushbutton.

### 6.6 Using the A-frame Fault Finder

The A-frame is used to pinpoint coating defects along the pipeline. It does this by measuring the voltage in the ground caused by the vLocDM signal current entering the pipe at a fault. It is necessary to make a physical/electrical contact with the ground. The A-frame has two spikes to facilitate this. Although the spikes are a few inches long, it is usually only necessary to puncture the ground with the spikes. Inserting them fully is only necessary where the ground conditions are particularly dry or high resistance.

The A-frame should be plugged into the accessory port. The receiver will automatically recognise the A-frame and enter the fault find mode.

## 6 Using the vLocDM Receiver

### 6.6.1 Fault Finding Method

1. Connect the transmitter as previously described. Select either 3Hz/6Hz/98Hz (ELF1) or 3Hz/6Hz/128Hz (ELF2) depending on mains frequency as previously described.
2. Connect the A-frame as above.

### 6.6.2 Using the A-frame

If the position of a defect has been identified by the vLocDM using the current gradient technique, start an A-frame survey approximately 20 meters before this point. Place the A-frame in the ground with the A-frame in line, the green pin pointing towards the suspected fault and directly above the pipe. The signal strength will be displayed, if the signal is strong enough an arrow will point forward and press the "+" pushbutton to save the reading. This will enter the result into the graph. Pressing the "-" pushbutton will delete the last record.

The searching of the graph is automated and may change as points are added.

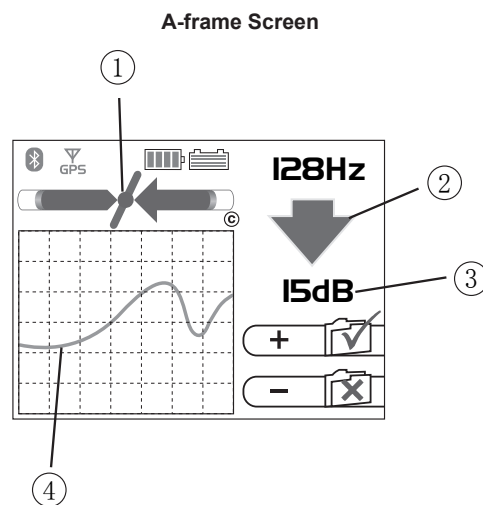
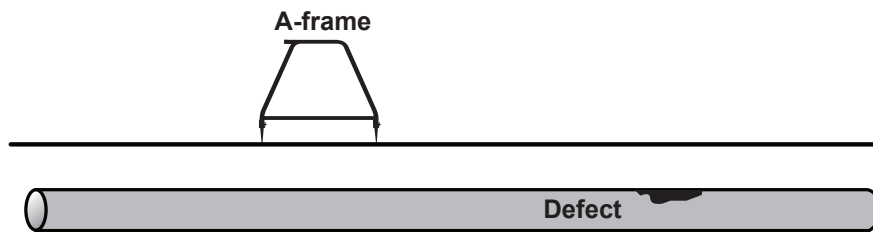

1	Locate Icon
2	Fault Direction
3	Fault Signal
4	Graph

**TIP**



The locate icon (1) will still be active whilst using the A-frame and should be used to ensure the A-frame is used directly above the pipe. However, adjustments to sensitivity/mode/frequency can only be made when in the Locate Screen. It is possible to jump to the Locate Screen by pressing the “Return” pushbutton. Make the desired adjustments in the Locate Screen and then jump back to the A-frame Screen by again pressing the “Return” pushbutton.

Continue walking in the direction of the arrow placing the A-frame in the ground at approximately one meter intervals saving the results as you go. The graph will rise as the defect is approached and then fall at the defect. Continuing past the defect will create a similar but reversed effect. A typical defect “signature” is shown below.

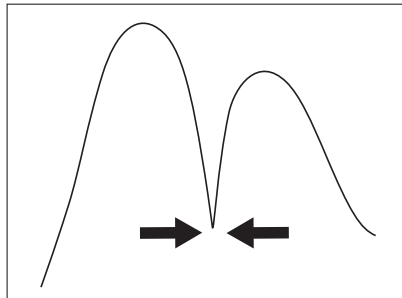

**NOTE**



If GPS is not activated, the horizontal intervals are assumed to be equal. If a GPS option is activated, the intervals are still shown as equal on the graph but the internal data log stores the GPS coordinates with the GPS data. This is because the accuracy of the GPS function tends to be less accurate than is what is required for A-frame fault finding.

To delete the log, press and hold the “-” pushbutton. A message will be displayed as shown in the screen below.

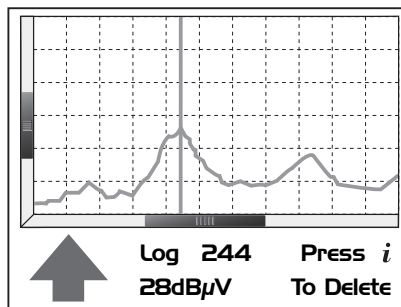

Press the “+” pushbutton to confirm to delete the log or “-” pushbutton to return to the graph.

At the null point, the arrows will reverse; this is the location of the defect. Repeating the procedure across the pipeline will help pinpoint the defect in the other plane. See diagram below.

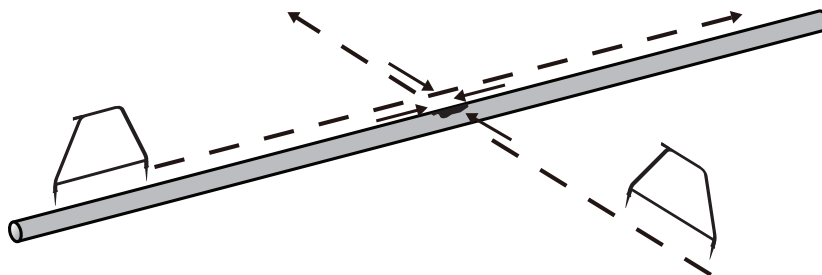

## 6 Using the vLocDM Receiver

Sometimes it is not possible to gain access to the pipe position. If this is the case walking along the route of the pipe a few meters to one side can very often produce good results. This procedure is also useful where the pipe runs under "blacktop" which acts as an insulator preventing the A-frame from making a good connection to ground.

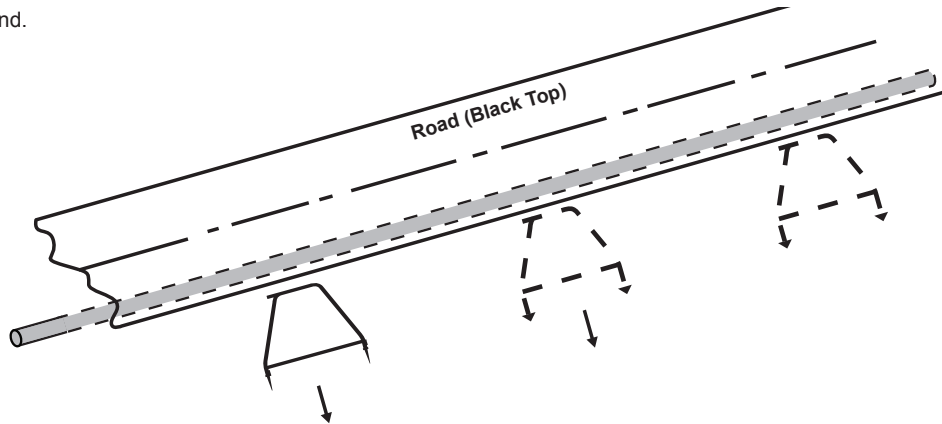

### 6.6.3 Using the A-frame where there are Many Defects Such As Porous Coating

Poorly coated pipelines such as old bituminous coating, may create a confusing result when as multiple defects will interfere with each other. To overcome this, it is sometimes beneficial to adopt a different approach.

This alternative approach involves using the A-frame perpendicular and to one side of the pipeline. See diagram below:

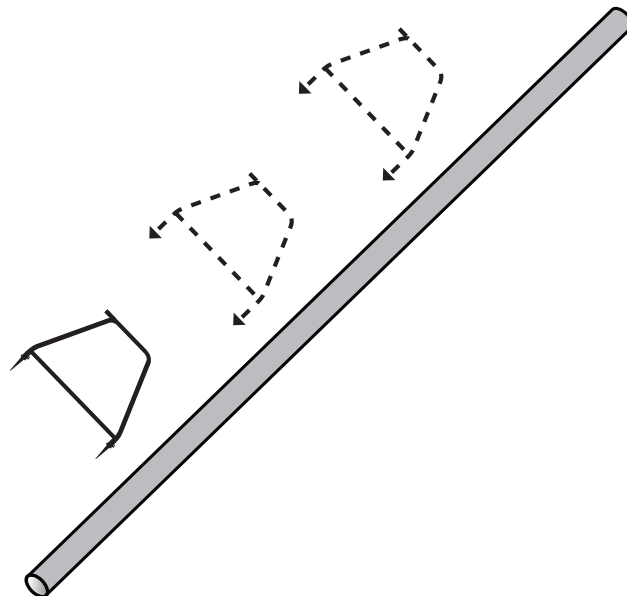

## 6 Using the vLocDM Receiver

Note the depth of the pipeline. Move approximately this distance to one side. Keep the orientation as above, walk along the section of pipeline taking readings at regular intervals. A typical result is shown below with the main defect being the largest reading. Note that the arrow will always point to the pipe, ie will not reverse unless the signal reduces to a level that cannot be processed correctly.

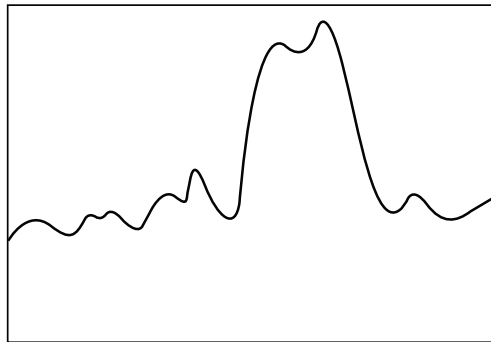

**A-frame Review Screen**

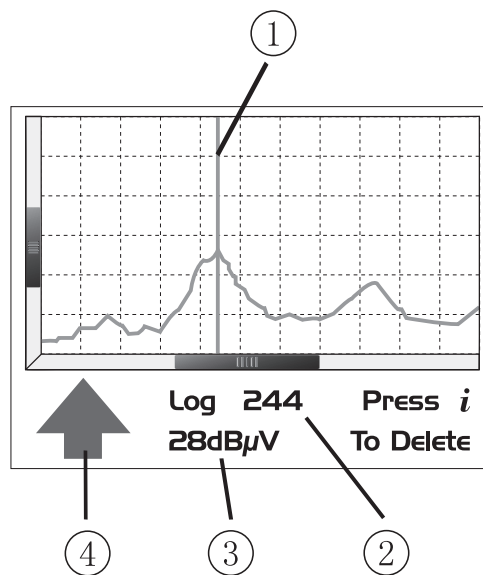

1	Position Indicator Bar
2	Record number at this point
3	A-frame fault intensity reading at this point
4	A-frame fault direction at this point

When in the graphing screen, pressing and holding the “i” pushbutton enters into the Review Screen. This enables the user to scroll through the logged points. A blue vertical line identifies the log position. At each position the A-frame readings are shown at the bottom of the graph. To delete a record press the “i” pushbutton. The unit will ask the user to confirm by pressing the “+” pushbutton.

To return to the Graph Screen press the “Return” pushbutton.

## Using an External GPS Data Logger

### 7.1 *Compatible GPS and GPS Data Loggers*

The vLocDM is compatible with most Bluetooth operated systems. However, the system has been tried and tested using the standalone GPS system "M-1200 Wireless GPS Receiver" from "HOLUX" and also "Trimble" system from "Tri-Global." Vivax-Metrotech reserve the right to alter or add to this list.

When using the Bluetooth to connect to the external device the system must first be "Paired".

To pair a device, first switches on the Bluetooth device. Then switch on the vLoc receiver and enter the menu by a prolonged press of the "i" pushbutton. Scroll down the options using the "+"/"-" pushbuttons until "Bluetooth pairing" is highlighted. Press the "Return" pushbutton.

The unit will search for available Bluetooth devices. After a few seconds, a list of devices will be shown. Highlight the appropriate device using "+"/"-" pushbuttons and then press the "Return" pushbutton to select the device.

The system is now paired with this device. It will not be necessary to pair again unless the unit is paired with a different device. That is to say the locator can only be paired with one unit at a time.



#### NOTE

The internal Bluetooth device may affect the operation of the "Radio Mode". When using "Radio Mode" disable the internal Bluetooth device by entering the menu (long press i) and selecting disable "Bluetooth Search".

### 7.2 *Transferring Data to a PC*

To transfer data from the vLocDM to a PC requires the use of the dedicated Uploader applications program. The Uploader can be downloaded from the the Vivax-Metrotech website, [www.vivax-metrotech.com](http://www.vivax-metrotech.com).

To upload a data file to PC double click on the vLocDM Uploader icon on your desktop. Connect a USB lead from the vLocDM to the PC. The program will detect the vLocDM locator and display "Locator detected".

Press the "Log Upload" button. The contents of the locator will be saved to your PC. Import the file to an Excel spread sheet or similar, for detailed analysis.

# Interpreting Results

## 8.1 Introduction

Using the vLocDM system can quickly and efficiently assess the general coating of a pipeline network. It can help identify defects and possible shorts to other structures. It can be used as a tool to prioritise and plan work on the network. However, unless care is taken when interpreting the results, misinterpretation can lead to unnecessary work and expenses.

## 8.2 Sources of Error

Most errors are either caused by carelessness in taking readings or by interference (or distorted signal field).

### 8.2.1 Operator Error

It is essential that care is taken when taking readings. Great care should be taken to pinpoint the position of the pipeline before a measurement is taken. The locator must be aligned and held vertically. The measurements are only as good as the care taken to obtain them.

The sensors used to detect the low frequency vLocDM profiling signal are very sensitive to low frequencies. Moving the instrument whilst the unit is calculating the information will cause the strong earths magnetic field to induce an interfering signal into the sensors resulting in errors. The vLocDM must be kept absolutely still whilst it is taking measurements.

### 8.2.2 Interference (Distorted Fields)

The vLocDM evaluates the electromagnetic field signal radiating from a pipeline to determine the information required. It assumed that the field is radiating from the pipe in an uniform way. Unfortunately the field is prone to being distorted and this can lead to errors.

#### 8.2.2.1 Source of Interference (Distorted Fields)

There are many sources of field distortion but this handbook lists some of the more common sources of distortion:

- i) Changes in Pipeline Direction
- ii) Adjacent Pipes or Cables
- iii) Cross Bonding
- iv) Passing Vehicles
- v) Pipe Sleeving

- i) Changes in Pipeline Direction

Whenever there is a change in pipeline direction there will be some field distortion. See diagram below. The sharper the change, the bigger the distortion. Avoid taking measurements at these points.

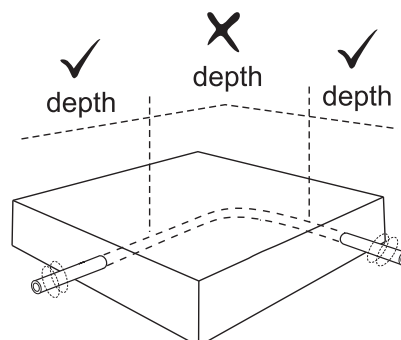

## 8 Interpreting Results

### ii) Adjacent Pipes or Cables

Adjacent pipelines or cables very often have a signal induced onto them by capacitance or inductive effects. These signals will interfere with the signal on the target pipe and will cause distortion. See diagram below.

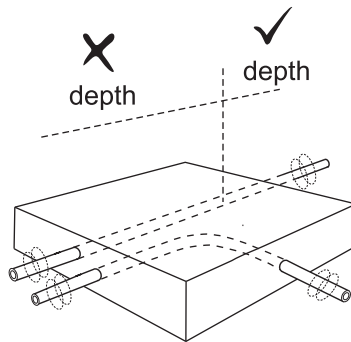

### iii) Cross Bonding

Pipes can often be cross bonded. This is a deliberate action designed to reduce the number of CP stations and to limit the effects of stray currents.

If the pipes are laid in the same path and are in close proximity the currents flowing on the two pipes will interfere with each other and cause interference. For best results the cross bonding should be disconnected for duration of the survey.

### iv) Passing Vehicles

The sensing devices used to detect the 3Hz vLocDM profiling signal are very sensitive to low frequencies. Vehicles passing very close to the receiver will disturb the earth's magnetic field and cause distortion of the received signal. Try to take measurements when there is a gap in passing vehicles.

In areas where traffic is passing, wait until three constant consecutive readings have been shown before saving result.

### v) Pipe Sleeving

It is common practice to insert a pipe in a protective steel sleeve. This may distort the signal and cause errors. Take readings before and after the sleeve. If they are the same, the pipeline is well insulated through the sleeve. Sleeves are very often used at road crossings.

### 8.2.2.2 Checking for Distorted Fields

Check to see if the signal is being distorted by other radiated fields. Locate the pipe, first in the "Peak" mode, and then in the "Null" mode. The two locates should indicate that the pipe is in the same place. If they do not, the signal field is distorted.

If the antenna mode, "Peak with arrows", is selected the same can be achieved without having to switch between modes. To do this, first find the position of the pipe using the largest bar graph reading as above. Then, find the position as indicated by the arrows. The arrows will indicate the same position as the null response of the bar graph. Hence, if the arrows and bar graph indicate the same position there is unlikely to be significant field distortion.

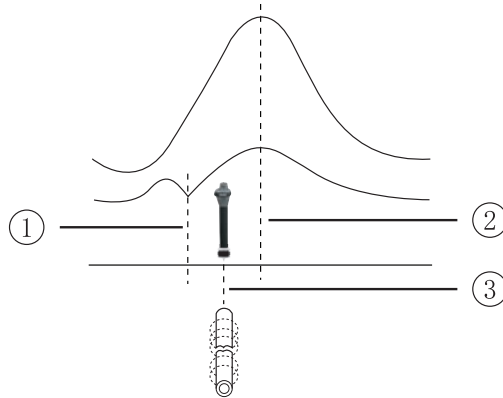

1	Null Position
2	Peak Position
3	True Position

### 8.3 Downloading Data to a PC

The vLocDM Uploader can be download from Vivax-Metrotech website, [www.vivax-metrotech.com](http://www.vivax-metrotech.com). This application allows the use of the vLocDM data in standard spread sheets such as Microsoft Excel.

The application is compatible with Windows 2000, Windows XP and Windows Vista.

#### Upload Log to PC and Clear Log in Receiver:

- Once the application's loaded to the PC a shortcut should appear on the PC desktop similar to the icon below.

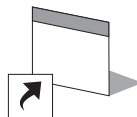

Shortcut to Vivax\_Log\_Uploaded V1.0.exe.Ink

- Connect the receiver to the PC using a USB cable. The PC should detect that there is a USB device connected. Double click on the Uploader icon as above. The following screen will be shown on the PC.

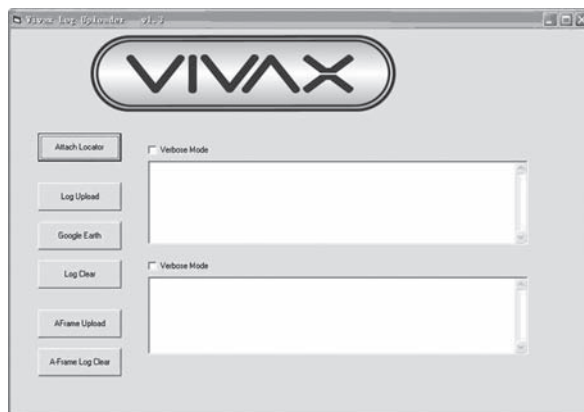

## 8 Interpreting Results

3. Click on the "Attach Locator" icon. Do not check the Verbose boxes. The top box will indicate that the locator is detected.
4. Now click on "Log Upload" or "A-frame Upload" if the A-frame data log is required.
5. The PC will request a folder location and .txt file name. Browse to your preferred folder location and allocate a name. Then press "open" to save the file.
6. The above screen will then be shown again. It is possible at anytime to clear the receiver's log by clicking on the "Log Clear" icon. Be sure that the file has been saved before clearing the log.
7. Press "Google Earth" to create a .kml Google Earth file.

### Importing a .txt File into an Excel Spreadsheet for Graphing and Analysis:

1. Open the Excel application.
2. Select the "Open new file" option and browse to the folder holding the .txt DM saved files. Select .txt type files. Open the .txt file to be worked on. Something similar to the screen below will be shown.

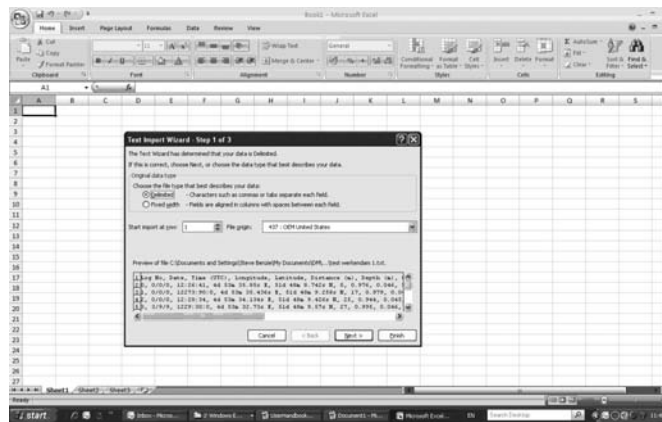

3. Check the "Delimited" option and click on "Next". The following screen should be shown.

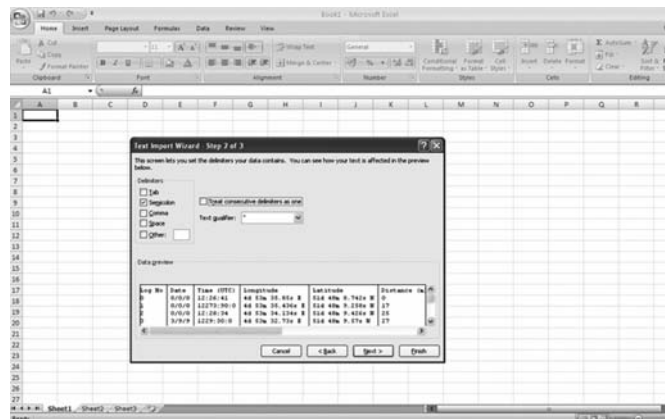

4. Check the "Semicolon (:)" box. Then click on the "Finish" box. Something similar to the screen below will be displayed.

## 8 Interpreting Results

Log No.	Date	Time (UTC)	Longitude	Latitude	Distance (m)	Depth (m)	Current (A)	Frequency (Hz)	Mode	DM Current (A)	DM Current Direction
1	8/1/19	12:26:41	46°51m 35.85s E	51°46m 8.742s N	0	0	0.976	0.046	98 Peak	0.1532	Forwards
2	8/1/19	12:27:54	46°51m 35.436s E	51°46m 9.226s N	17	17	0.976	0.047	98 Peak	0.1562	Forwards
3	8/1/19	12:28:34	46°51m 34.134s E	51°46m 9.426s N	25	25	0.944	0.045	98 Peak	0.1561	Forwards
4	8/1/19	12:29:30	46°51m 32.732s E	51°46m 9.573s N	27	27	0.990	0.046	98 Peak	0.1600	Forwards
5	8/1/19	12:30:27	46°51m 31.272s E	51°46m 9.676s N	28	28	0.976	0.046	98 Peak	0.1595	Forwards
6	8/1/19	12:31:10	46°51m 29.874s E	51°46m 9.755s N	26	26	0.942	0.039	98 Peak	0.1768	Forwards
7	8/1/19	12:33:34	46°51m 28.398s E	51°46m 9.833s N	28	28	0.976	0.039	98 Peak	0.1290	Forwards
8	8/1/19	12:36:17	46°51m 27.834s E	51°46m 9.833s N	26	26	1.102	0.029	98 Peak	0.1813	Forwards
9	8/1/19	12:38:17	46°51m 27.834s E	51°46m 9.473s N	20	20	1.1	0.029	98 Peak	0.1511	Forwards
10	8/1/19	12:41:23	46°51m 28.322s E	51°46m 9.513s N	22	22	0.955	0.031	98 Peak	0.1324	Forwards
11	8/1/19	12:42:28	46°51m 28.538s E	51°46m 9.379s N	13	13	1.065	0.016	98 Peak	0.0346	Forwards
12	8/1/19	12:51:48	46°51m 28.826s E	51°46m 9.765s N	20	20	0.851	0.008	98 Peak	0.0321	Forwards

The data is now in the form of an Excel spreadsheet and can be manipulated to create suitable graphs.

In the example above, the Distance column is filled automatically, as the GPS option was used when data was collected. If GPS was not used, the distance between measurements will have to be inserted manually.

It is advisable to insert a column in the spreadsheet for accumulated distance (This process is automatically done on some recent software revisions). This will make the graphing process easier.

This can be done long hand or doing the following will speed up the action.

1. Insert a column by right clicking over the Depth (m) column and select insert column. Name the new column "Accumulated Distance".
2. Insert 0 at the top cell, first Accumulated Distance.
3. Place the pointer over the second empty Accumulated Distance cell and key in "=", then click on the second Distance cell, then key in "+", then click on the first Accumulated Distance cell in the Excel sheet. Now press "Enter" on the keyboard, the second Accumulated Distance is calculated.
4. Now left click on the corner of second Accumulated Distance cell and drag the corner of the box down to the bottom of the column. The boxes should fill with the Accumulated Distance as below.

Log No.	Date	Time (UTC)	Longitude	Latitude	Distance (m)	Accumulated Distance	Depth (m)	Current (A)	Frequency (Hz)	Mode	DM Current (A)	DM Current Direction
1	8/1/19	12:26:41	46°51m 35.85s E	51°46m 8.742s N	0	0	0	0.976	0.046	98 Peak	0.1532	Forwards
2	8/1/19	12:27:54	46°51m 35.436s E	51°46m 9.226s N	17	17	17	0.976	0.047	98 Peak	0.1562	Forwards
3	8/1/19	12:28:34	46°51m 34.134s E	51°46m 9.426s N	25	42	42	0.944	0.045	98 Peak	0.1561	Forwards
4	8/1/19	12:29:30	46°51m 32.732s E	51°46m 9.573s N	27	69	69	0.990	0.046	98 Peak	0.1600	Forwards
5	8/1/19	12:30:27	46°51m 31.272s E	51°46m 9.676s N	28	97	97	0.976	0.046	98 Peak	0.1595	Forwards
6	8/1/19	12:31:10	46°51m 29.874s E	51°46m 9.755s N	26	123	123	0.942	0.039	98 Peak	0.1768	Forwards
7	8/1/19	12:33:34	46°51m 28.398s E	51°46m 9.833s N	28	151	151	0.976	0.039	98 Peak	0.1290	Forwards
8	8/1/19	12:36:17	46°51m 27.834s E	51°46m 9.833s N	26	179	179	1.102	0.029	98 Peak	0.1813	Forwards
9	8/1/19	12:38:17	46°51m 27.834s E	51°46m 9.473s N	20	199	199	1.1	0.029	98 Peak	0.1511	Forwards
10	8/1/19	12:41:23	46°51m 28.322s E	51°46m 9.513s N	22	221	221	0.955	0.031	98 Peak	0.1324	Forwards
11	8/1/19	12:42:28	46°51m 28.538s E	51°46m 9.379s N	13	234	234	1.065	0.016	98 Peak	0.0346	Forwards
12	8/1/19	12:51:48	46°51m 28.826s E	51°46m 9.765s N	20	254	254	0.851	0.008	98 Peak	0.0321	Forwards

- It is now possible to generate a graph. Graphs are most commonly done as DM Current against Distance.
- Highlight the Accumulated Distance records and then press the "Ctrl" key whilst highlighting the DM Current column.
- From the "Insert" tab, select "Scatter Plot". And from the menu, select the desired graph. The graph will then be generated as below.

## 8 Interpreting Results



The graph is drawn with a linear current x axis. If a logarithmic scale is required, right click on the x axis and select logarithmic from the options as below.



### Saving a Google Earth File

1. It is possible to save a DM Log file as a Google Earth .kml file. To do this, connect the locator to the PC as if getting ready to download a normal DM file. Instead of clicking on the "Log Upload" button, choose "Google Earth".
2. The Application will ask where you want the file to be placed. Select a file location and save the file. A .kml file will automatically be created.
3. To launch a .kml file, double click on the selected file. If connected to the web and if Google Earth application is installed on the host computer, Google Earth will automatically launch and will zoom to the site location. Pins will indicate survey points. Clicking on a point will show measurement details for that point.



### 8.4 Interpreting Graphs

There are two types of graphs that can be plotted. These can either be plotted.

1. Linear
2. Logarithmic

In either case, it is important to look at the trend of the graph rather than individual points. This is because the signals radiating from a pipe can be affected by many external influences such as:

- passing cars
- ground currents from stray currents
- ground currents from the transmitter
- slight movements of the receiver

This is just a few examples, the list is probably endless.

The intention is to identify changes in current which signify a defect. So if we were to look at a small section of graph it is, incorrectly, possible to interpret fluctuations as a defect. See diagram below.

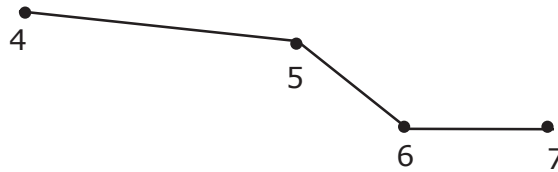

Section Points 4-7 of Graph A

Just taking points 4/5/6/7 is possible to think that there is a defect at this point. However, looking at points 1 to 20 shows that there is in fact a trend of signal loss at points 10-13, which is the more likely fault location.

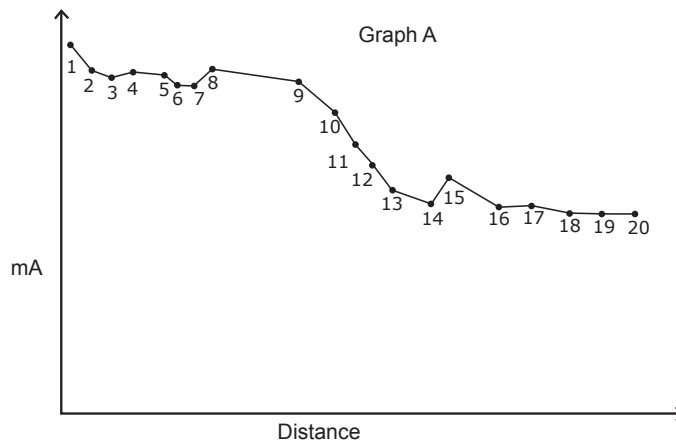

Also note the step response at points 1 to 2. This is typical of readings near the application point and may not represent a fault. The step is very often caused by the concentration of ground currents at the application point or the cable leading to the ground bed. If in doubt, check the section using the A-frame.

Whether Logarithmic or Linear scales are used is a matter of personal preference. However, when looking for defects along a pipe, similar defects, further along the pipe can appear smaller than those near the application point. This is because there is less pickup at distance as the signal from the transmitter is reduced. Using a logarithmic scale has the effect of compensating for this effect and is more likely to represent the true magnitude of the defect which is a long way down the pipeline.

## Care and Maintenance

### 9.1 Cleaning

Cleaning can be done with a cloth dampened with warm soapy water. Do not use scouring pads on the casing or display surfaces as this will scratch the device. Do not submerge or pour water over the receiver or transmitter.

Always dry the equipment before storing.

### 9.2 Checking Functionality

The vLocDM system can be checked using a simple test procedure. It requires an area clear of pipes and cables and free from metallic structures such as metal tanks, metal railings and reinforced concrete.

A 40m square loop of wire needs to be set out on the ground with a non metallic structure placed at 1m above the cable and at the mid point of one of the straight sections. See diagram below.

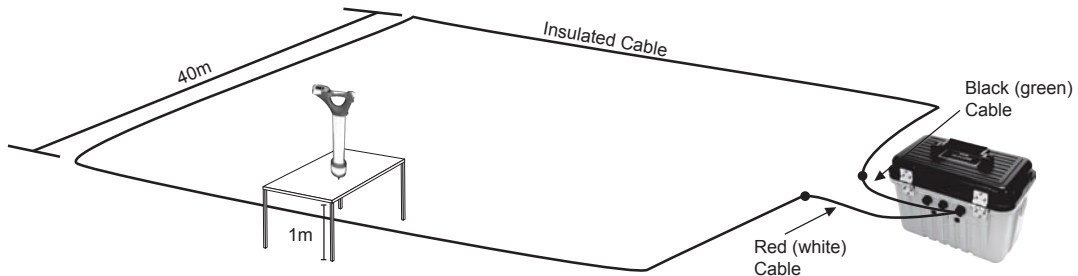

#### Method:

1. Set the transmitter to 128Hz (98Hz if in a 60Hz environment)/3Hz/6Hz. Set the current to 100mA.
2. Set the locator to receive 128Hz (or 98Hz). Position the locator on the non-metallic structure and carefully align so that it is above and in line with the cable. Set the gain of the locator to read approximately 50%. Check that the line indicator is pointing "North/South", if it is not there could be an interfering signal or you may be too near to a bend of the loop.
3. Hold the locator very still and press the "i" pushbutton. After a few seconds, a result will be displayed on the instrument.
4. Check that the arrow is pointing back towards the white connection lead.
5. Check the vLocDM current reading is 100mA +/-10mA (10%).
6. Check the depth is 1m +/- 7cm.
7. Repeat for each of the current settings of the transmitter.
8. Successful completion of these tests confirms that both the receiver and transmitter are functional.

# Data Sheet

## 10.1 vLocDM Receiver

### A. Typical Applications

Item	Parameter
Description	Pipeline defect mapper receiver
Uses	<ul style="list-style-type: none"> <li>• Locating and pinpointing coating defects on buried pipelines</li> <li>• Profiling the CP current distribution on a pipeline network</li> <li>• Identification of short circuits from pipelines to other structures</li> <li>• Long distance pipeline location</li> </ul>

### B. Receiver Assembly

Item	Parameter
Construction	<ul style="list-style-type: none"> <li>• Carbon fiber reinforced antenna tube</li> <li>• High impact thermoplastic (ABS) injection molded housing</li> <li>• ABS foot molding containing magnetometer</li> </ul>
Weight	7.5lbs (3.4kg)
Dimension	11.7" (L) x 5.5" (W) x 30.4" (H) (298 (L) x 140 (W) x 772 (H) mm)
Display Type	Sharp TFT LCD ¼ VGA color display, 3.52" (89mm)
Receiver Antennas	<ul style="list-style-type: none"> <li>• 2 x horizontal &amp; 1 x 90 degree antenna &amp; 1 x null antenna – Air cored</li> <li>• 1 x magnetometer for low frequency DM measurements</li> </ul>
Batteries	<ul style="list-style-type: none"> <li>• Rechargeable (6 x AA Ni-MH) batteries (internal) with 100-240V AC mains charger</li> <li>• Replaceable (6 x standard alkaline AA batteries) batteries can be used when required</li> </ul>
Battery Life	<ul style="list-style-type: none"> <li>• Alkaline – typically 6 hrs intermittent use at 70°F (21°C)</li> <li>• Ni-MH – typically 6 hrs intermittent use at 70°F (21°C)</li> <li>• Re-charging cycles approx. 500 times life cycle</li> </ul>
Bluetooth	<ul style="list-style-type: none"> <li>• Optional Internal Bluetooth link for interfacing specified Bluetooth enabled GPS/Data Loggers</li> </ul>
External Connectors	<ul style="list-style-type: none"> <li>• 1 x round USB socket for accessories</li> <li>• 1 x mini USB socket for data transfer and programming</li> <li>• 1 x socket for battery charger</li> </ul>
Approvals	<ul style="list-style-type: none"> <li>• Complies with European standard CE (Directive 99/5/EC) <ul style="list-style-type: none"> <li>• EN 61000-6-4: 2007</li> <li>• EN 61000-4-3: 2006</li> <li>• EN 61000-4-2: 1995 A1 &amp; A2</li> <li>• EN 61000-4-8: 1994 A1</li> <li>• ETSI EN 300 330-2 : 2006</li> <li>• ETSI EN 301 489-1 : 2005</li> <li>• ETSI EN 301 489-3 : 2002</li> </ul> </li> <li>• Complies with FCC Rules Part 15 <ul style="list-style-type: none"> <li>• CFR 47 part 2 : 2004</li> <li>• CFR 47 Part 15 : 2006</li> <li>• ANSI C63.4: 2003</li> </ul> </li> </ul>

Item	Parameter
Standard Accessories	<ul style="list-style-type: none"> <li>• USB data cable</li> <li>• 100-240V AC mains charger</li> <li>• Soft carry bag for vLocDM receiver</li> <li>• User handbook</li> <li>• GPS (external)</li> <li>• Bluetooth (internal)</li> </ul>
Accessories (Option)	<ul style="list-style-type: none"> <li>• A-frame</li> <li>• Auxilliary rechargeable battery pack (fits in place of alkaline batteries) charged externally</li> <li>• Vehicle charging lead</li> <li>• Sondes (waterproof self-contained transmitters for use in pipes &amp; ducts)</li> <li>• D18-33-SR44 - 0.75" (18mm) (Dia.) x 3.1" (80mm) (L), 33 kHz, range 12ft (4m), 2 x button cell batteries</li> <li>• D38-33-AA – 1.5" (38mm) (Dia.) x 4.1" (105mm) (L), 33 kHz, range 15ft (5m), 1 x AA battery</li> <li>• D64-33-LR61 – 2.5" (64mm) (Dia.) x 7.3" (186mm) (L), 33 kHz, range 24ft (8m), 1 x LR61 battery</li> <li>• D23F-512-AA / D23F-640-AA – 1" (23mm) (Dia.) x 18" (456mm) (L), 512Hz or 640Hz, range 20ft (7m), flexible Sonde in 3 sections for use in cast iron pipes as well as non metallic pipes, 1 x AA battery</li> </ul>

**C. Operational**

Item	Parameter
Information Displayed	<ul style="list-style-type: none"> <li>• Signal strength - moving bar graph &amp; numeric value</li> <li>• Mode indication ("Peak", "Null", "Broad Peak", "Sonde", and "Peak with proportional left/right arrows" location)</li> <li>• Proportional left/right indication</li> <li>• Compass: line direction indicator</li> <li>• vLocDM Signal Direction</li> <li>• Automatic recognition of accessories</li> <li>• Peak signal response indication</li> <li>• Null signal response indication</li> <li>• Broad Peak signal response indication</li> <li>• Measurement of depth and current on target line</li> <li>• Depth measurement in active modes including 50/60 Hz</li> <li>• Measurement of vLocDM mapping current</li> <li>• Gain level (in dB)</li> <li>• Internal and external battery condition</li> <li>• Speaker volume</li> <li>• Operating frequency</li> <li>• Distance from last reading (when GPS facility activated)</li> <li>• Log number</li> <li>• Real time vLocDM mapping and on screen graphing (walk back feature)</li> <li>• Real time A-frame fault mapping and on screen graphing</li> </ul>

Item	Parameter																																																																		
Configuration	<p>Intuitive setup menu enables user to configure:</p> <ol style="list-style-type: none"> <li>1. Selection “favourites” list of frequencies to toggle</li> <li>2. Sonde/line location</li> <li>3. Units of measure (feet/meter)</li> <li>4. Power Mode – 50Hz or 60Hz environments</li> <li>5. Sound (Pitch) – normal/modulated</li> <li>6. Favorite mode selection</li> <li>7. Language</li> <li>8. Continuous depth option</li> <li>9. Continuous signal current option</li> <li>10. Speaker level</li> <li>11. Backlight level</li> </ol>																																																																		
Operating Frequencies	<p>vLocDM (magnetometer) frequencies: 3Hz/6Hz , 4Hz/8Hz                      vLocDM related locate frequencies: 98Hz, 128Hz, 512Hz, 640Hz                      General locating frequencies included as follows:</p> <table border="1" data-bbox="576 858 1270 1479"> <tbody> <tr><td>Power 50 (50+150+250Hz)</td><td>460Hz</td><td>8.44 kHz (8,440Hz)</td></tr> <tr><td>Power 60 (60+180+300Hz)</td><td>480Hz</td><td>9.5 kHz(9,500Hz)</td></tr> <tr><td>Radio Mode (22.1 kHz)</td><td>484Hz</td><td>9.82 kHz(9,820Hz)</td></tr> <tr><td>RF EUR (19.8 kHz)</td><td>491Hz</td><td>16.9 kHz(16,900Hz)</td></tr> <tr><td>50Hz</td><td>512Hz</td><td>22.5 kHz(22,500Hz)</td></tr> <tr><td>60Hz</td><td>560Hz</td><td>29.4 kHz(29,430Hz)</td></tr> <tr><td>64Hz</td><td>577Hz</td><td>CATV(31,468Hz)</td></tr> <tr><td>98Hz</td><td>604Hz</td><td>32.8 kHz(32,768Hz)</td></tr> <tr><td>CP 100</td><td>624Hz</td><td>38.0 kHz(38,000Hz)</td></tr> <tr><td>CP 120</td><td>640Hz</td><td>65.5 kHz(65,536Hz)</td></tr> <tr><td>128Hz</td><td>680Hz</td><td>78.125 kHz(78,125Hz)</td></tr> <tr><td>163Hz</td><td>760Hz</td><td>78.132 kHz(78,132Hz)</td></tr> <tr><td>208Hz</td><td>800Hz</td><td>80.4 kHz(80,430Hz)</td></tr> <tr><td>220Hz</td><td>815 kHz</td><td>82 kHz(82,132Hz)</td></tr> <tr><td>256Hz</td><td>920 kHz</td><td>82.5 kHz(82,488Hz)</td></tr> <tr><td>273Hz</td><td>968 kHz</td><td>83.1 kHz(83,077Hz)</td></tr> <tr><td>280Hz</td><td>982 kHz</td><td>89 kHz(89,000Hz)</td></tr> <tr><td>320Hz</td><td>1.02 kHz (1,024Hz)</td><td>118 kHz(117,850Hz)</td></tr> <tr><td>340Hz</td><td>1.17 kHz (1,170Hz)</td><td>121 kHz(121,000Hz)</td></tr> <tr><td>380Hz</td><td>1.45 kHz (1,450Hz)</td><td>128 kHz(128,000Hz)</td></tr> <tr><td>400Hz</td><td>8.01 kHz (8,010Hz)</td><td>131 kHz(131,072Hz)</td></tr> <tr><td>440Hz</td><td>8.19 kHz (8,192Hz)</td><td>200 kHz(200,000Hz)</td></tr> </tbody> </table> <p>Vivax-Metrotech Corporation retains the right to make additions or deletions to this list at any time</p>	Power 50 (50+150+250Hz)	460Hz	8.44 kHz (8,440Hz)	Power 60 (60+180+300Hz)	480Hz	9.5 kHz(9,500Hz)	Radio Mode (22.1 kHz)	484Hz	9.82 kHz(9,820Hz)	RF EUR (19.8 kHz)	491Hz	16.9 kHz(16,900Hz)	50Hz	512Hz	22.5 kHz(22,500Hz)	60Hz	560Hz	29.4 kHz(29,430Hz)	64Hz	577Hz	CATV(31,468Hz)	98Hz	604Hz	32.8 kHz(32,768Hz)	CP 100	624Hz	38.0 kHz(38,000Hz)	CP 120	640Hz	65.5 kHz(65,536Hz)	128Hz	680Hz	78.125 kHz(78,125Hz)	163Hz	760Hz	78.132 kHz(78,132Hz)	208Hz	800Hz	80.4 kHz(80,430Hz)	220Hz	815 kHz	82 kHz(82,132Hz)	256Hz	920 kHz	82.5 kHz(82,488Hz)	273Hz	968 kHz	83.1 kHz(83,077Hz)	280Hz	982 kHz	89 kHz(89,000Hz)	320Hz	1.02 kHz (1,024Hz)	118 kHz(117,850Hz)	340Hz	1.17 kHz (1,170Hz)	121 kHz(121,000Hz)	380Hz	1.45 kHz (1,450Hz)	128 kHz(128,000Hz)	400Hz	8.01 kHz (8,010Hz)	131 kHz(131,072Hz)	440Hz	8.19 kHz (8,192Hz)	200 kHz(200,000Hz)
Power 50 (50+150+250Hz)	460Hz	8.44 kHz (8,440Hz)																																																																	
Power 60 (60+180+300Hz)	480Hz	9.5 kHz(9,500Hz)																																																																	
Radio Mode (22.1 kHz)	484Hz	9.82 kHz(9,820Hz)																																																																	
RF EUR (19.8 kHz)	491Hz	16.9 kHz(16,900Hz)																																																																	
50Hz	512Hz	22.5 kHz(22,500Hz)																																																																	
60Hz	560Hz	29.4 kHz(29,430Hz)																																																																	
64Hz	577Hz	CATV(31,468Hz)																																																																	
98Hz	604Hz	32.8 kHz(32,768Hz)																																																																	
CP 100	624Hz	38.0 kHz(38,000Hz)																																																																	
CP 120	640Hz	65.5 kHz(65,536Hz)																																																																	
128Hz	680Hz	78.125 kHz(78,125Hz)																																																																	
163Hz	760Hz	78.132 kHz(78,132Hz)																																																																	
208Hz	800Hz	80.4 kHz(80,430Hz)																																																																	
220Hz	815 kHz	82 kHz(82,132Hz)																																																																	
256Hz	920 kHz	82.5 kHz(82,488Hz)																																																																	
273Hz	968 kHz	83.1 kHz(83,077Hz)																																																																	
280Hz	982 kHz	89 kHz(89,000Hz)																																																																	
320Hz	1.02 kHz (1,024Hz)	118 kHz(117,850Hz)																																																																	
340Hz	1.17 kHz (1,170Hz)	121 kHz(121,000Hz)																																																																	
380Hz	1.45 kHz (1,450Hz)	128 kHz(128,000Hz)																																																																	
400Hz	8.01 kHz (8,010Hz)	131 kHz(131,072Hz)																																																																	
440Hz	8.19 kHz (8,192Hz)	200 kHz(200,000Hz)																																																																	
Operating Modes	<ul style="list-style-type: none"> <li>• Peak (using two horizontal antennas)</li> <li>• Broad Peak (using one horizontal antenna)</li> <li>• Null (using one vertical antenna) with proportional left/right indications</li> </ul>																																																																		

## 10 Data Sheet

Item	Parameter
Data Storage and Data Handling	<ul style="list-style-type: none"> <li>• 1000 data point storage</li> <li>• Download of stored data to specific strategic partners' applications or to PC via Vivax-Metrotech desktop application for detailed analysis in dedicated analysis software or standard spread sheets such as Microsoft Excel.</li> </ul>
Gain Control	Press "+" or "-" pushbutton once to return to mid scale
Performance using single undistorted signal source	<p>Locate pinpointing accuracy:</p> <ul style="list-style-type: none"> <li>• up to 9ft (3m) – 5% of depth</li> <li>• over 9ft (3m) – 10% of depth</li> </ul> <p>Depth measurement accuracy:</p> <ul style="list-style-type: none"> <li>• 5% of depth</li> </ul> <p>Current measurement accuracy:</p> <ul style="list-style-type: none"> <li>• 5% of actual current – up to 9ft (3m)</li> <li>• 10% of actual current – over 9ft (3m)</li> </ul> <p>Depth range :</p> <p>Dependent on strength of signal radiating to locator – generally up to 15ft (5m)</p>
Compatible with Transmitter	Loc-150Tx, Loc-10Tx, Loc-5Tx

### D. Sensitivity

Mode	Sensitivity at 3.2ft (1m)
3Hz DM Mapping frequency	1 mA
50 Hz/ Power mode	7.5 mA
Radio mode	20 $\mu$ A
512 Hz / 640 Hz	400 $\mu$ A
8 kHz	40 $\mu$ A
32 kHz and above	25 $\mu$ A

### E. Environmental

Item	Parameter
Temperature Range	Operating : - 4°F to 122°F (-20°C to 50°C) Storage : - 40°F to 140°F (-40°C to 60°C)
Weather Proof	IP54 and NEMA 4
Shipping Weight	13.2lbs (6kg)
Shipping Dimension	13"(L) x 8.7"(W) x 32.7"(H) (330(L) x 220(W) x 830(H) mm)

### F. Warranty

Item	Parameter
Warranty	12 months

### G. A-frame Accessory

Item	Parameter
Construction	Carbon fiber glass
Sensitivity	Maximum fault resistance is 2M ohm defect
Weight	4lbs (1.80kg)
Dimension	28.3"(L) x 25.2"(W) x 1.6"(H) (720(L) x 640(W) x 40(H) mm)
Weather Proof	IP54
Shipping Weight	9.9lbs (4.50kg)
Shipping Dimension	31.5"(L) x 27.8"(W) x 4.5"(H) (800(L) x 705(W) x 115(H) mm)

**H. GPS**

Item	Parameter
Uses	Tracks up to 32 satellites
Update Rate	1Hz
Battery Life	Lithium-ion battery lasts for 15 hours of use
Temperature Range	Operating: 14°F to 140°F (-10°C to 60°C) Storage : -4°F to 140°F (-20°C to 60°C)
Operation Humidity	5% to 95% no condensing
Non DGPS(Differential GPS) Position	3m CEP without SA
Time	0.1 microsecond sync GPS time

**10.2 Loc-150Tx Transmitter****A. Typical Applications**

Item	Parameter
Description	Pipeline defect mapper transmitter
Uses	Transmitting active signals for the location of coating defects on buried pipes

**B. Transmitter Assembly**

Item	Parameter
Construction	High impact ABS
Weight	27.5lbs (12.5kg)
Dimension	16.7"(L) x 10.3"(W) x 12.9"(H) (425(L) x 262(W) x 328(H)mm)
Display type	Monochrome dot matrix display 2.4" (60mm) x 1.3" (32mm)
Power Supply	<ul style="list-style-type: none"> <li>• Cathodic Protection (nominally 50V DC)</li> <li>• 100 – 250V AC mains power</li> <li>• or 12V DC external supply (output is limited when using 12V DC)</li> </ul>
External Connectors	<ul style="list-style-type: none"> <li>• 100 – 250V AC mains input - three pin "Multi-Con-X" connector(Male)</li> <li>• 12V DC Input - two pin "Multi-Con-X" connector(Male)</li> <li>• Transmitter output - two pin "Multi-Con-X" connector(Female)</li> <li>• Fuse socket</li> </ul>
Output Protection	Output fuse protected against accidental connection to up to AC/DC 250V
Approvals	<ul style="list-style-type: none"> <li>• Complies with European standard CE (Directive 99/5/EC) (Pending)</li> <li>• EN 61000-6-4: 2007</li> <li>• EN 61000-4-3: 2006</li> <li>• EN 61000-4-2: 1995 A1 &amp; A2</li> <li>• EN 61000-4-8: 1994 A1</li> <li>• ETSI EN 300 330-2 : 2006</li> <li>• ETSI EN 301 489-1 : 2005</li> <li>• Complies with FCC Rules Part 15 (Pending)</li> <li>• CFR 47 part 2 : 2004</li> <li>• CFR 47 Part 15 : 2006</li> <li>• ANSI C63.4 : 2003</li> <li>• ETSI EN 301 489-3 : 2002</li> </ul>
Standard Accessories (supplied with transmitter)	<ul style="list-style-type: none"> <li>• 1 x direct connection lead (with two cables each 10ft (3.5m) long with crocodile clips)</li> <li>• 1 x DC input lead (with two cables each 10ft (3.5m) long with crocodile clips)</li> <li>• 1 x 3m mains input lead</li> </ul>

**C. Operational**

Item	Parameter
Information displayed	<ul style="list-style-type: none"> <li>• Output Frequency</li> <li>• Output Current setting</li> <li>• Output Current</li> <li>• Output Voltage (info menu)</li> <li>• Operating Temperature (info menu)</li> </ul>
Signal Application Modes	<ul style="list-style-type: none"> <li>• <b>Direct connection mode only</b>- applies signal directly to the cable by clipping one output lead to the pipe, the other to an independent ground or anode bed.</li> </ul>
Transmitting Frequencies (varies by country & market)	<ul style="list-style-type: none"> <li>• 98Hz, 128Hz, 512Hz, 640Hz, 3Hz/98Hz, 3Hz/128Hz, 4Hz/98Hz</li> <li>• 4Hz/128Hz, ELF1-3Hz/6Hz/98Hz;</li> <li>• ELF2-3Hz/6Hz/128Hz</li> <li>• ELF3-4Hz/8Hz/98Hz; ELF4-4Hz/8Hz/128Hz;</li> <li>• 3Hz/6Hz/512Hz;</li> <li>• 3Hz/6Hz/640Hz;</li> <li>• 4Hz/8Hz/512Hz;</li> <li>• 4Hz/8Hz/640Hz</li> </ul> <p>Other multiple frequencies in the range of 3Hz to 2 kHz available upon request.</p>
Transmitting Mode Power output	<p>Powered by AC: 150W          Powered by DC: 12-20V, 50W</p>
Output voltage	Maximum output voltage = 120V RMS
Output current	Maximum output current = 4A RMS with up to 2 frequencies. Output limited to 3A with three or four simultaneous frequencies.
Controls	<p>Uses 2 Rotary/Push control knobs to select:</p> <ul style="list-style-type: none"> <li>• Frequency</li> <li>• Output level</li> <li>• Information</li> <li>• ACTIVE/STANDBY pushbutton</li> <li>• One On/OFF pushbutton</li> </ul>
Compatible with Receiver	vLocDM

**D. Environmental**

Item	Parameter
Temperature Range	<p>Operating : -4°F to 122 °F (-20°C to 50°C)          Storage : -40°F to 140°F (-40°C to 60°C)</p>
Weather Proof	IP54 and NEMA 4
Shipping Weight	44.1lbs (20kg)
Shipping Dimension	21.7"(L) x 15.2"(W) x 18.3"(H) (550(L) x 385(W) x 465(H) mm)

**E. Warranty**

Item	Parameter
Warranty	12 months

# Glossary

Active Locate	A locate where a transmitter is used to apply a signal to a buried pipe or cable, the position of which is then located by a receiver tuned to the same frequency.
Active Signal	A signal applied by the locator transmitter to a buried line. Typical this is a very precise frequency.
Attenuation	The reduction of an electromagnetic signal from a pipe or cable.
Clamp (or Coupler)	An accessory used to apply the transmitter signal to an insulated line, removing the need to connect the transmitter signal directly to a conductor or cable sheath.
Compass	Line direction indicator. (Although visually like a compass, this is the only relation to a compass.)
Coupling	The act of signals transferring to lines to which they were not originally applied. Coupling can be "direct" where the target line has an electrical connection to another line, or "induced" where the signal radiates from the target line to another line or lines.
Display	The information visually available on the dot matrix display.
Line	A generic term for any buried pipe or cable.
Null	A minimum  response to a buried line.
Passive Locate	A locate where the receiver searches for a wide range of signals that radiate from buried pipes or cables. These signals come from a variety of sources in the environment and couple to the buried (& overhead) lines. Typical examples 50/60Hz and LF/VLF radio.
Passive Signals	A wide range of signals that radiate from buried pipes or cables. These signals come from a variety of sources in the environment and couple to the buried (& overhead) lines. Typical examples 50/60Hz and LF/VLF radio.
Peak	A maximum response to a buried line.
Pinpoint	Using a receiver to identify the exact position of a buried line.
Response	The indication that the receiver gives which is caused by the signals it is receiving. This can be visual, audio or both. Typically it is displayed on the locators dot matrix display and audibly from a loudspeaker in the receiver housing.
Search (sweep)	This describes the act of looking for a buried line within a given area.

## 11 Glossary

Sonde	A small transmitting coil which may be built into a product such as a sewer camera or packaged as a small self contained battery powered transmitter. A receiver tuned to the same frequency can locate the position of the Sonde and hence whatever it is attached to or in. Frequently used for locating sewer cameras, and the non metallic pipes.
Target Line	The buried pipe or cable to be located.
Trace	Using a locator to following the path of a buried line.

Illustrations used in the preparation of this manual will inevitably show some resemblance to similar illustrations from other manufacturers.-Some manufacturers have given permission for the use of their graphics (Metrotech & Seba) other manufacturers such as Radiodetection is given credit for these use. This statement is intended to attribute such credit.

**Disclaimer:** All product availability or product accessory information is subject to change without notice.

